

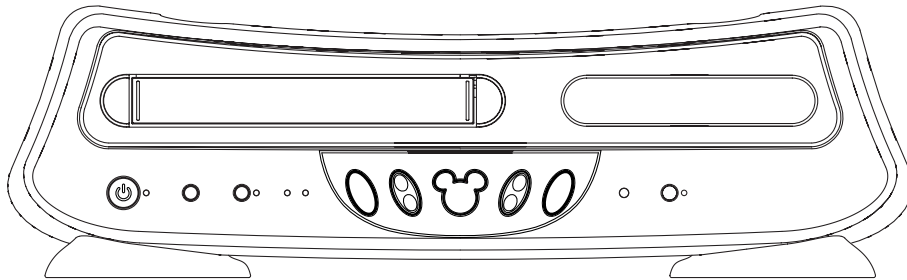

DVD2100-C

SERVICE MANUAL

DVD VIDEO PLAYER & VHS VIDEO CASSETTE RECORDER



**ORIGINAL
MFR'S VERSION A**

IMPORTANT WARNING

CAUTION:

DVD PLAYER IS A CLASS 1 LASER PRODUCT. HOWEVER THIS PLAYER USES A VISIBLE LASER BEAM WHICH COULD CAUSE HAZARDOUS RADIATION EXPOSURE IF DIRECTED. BE SURE TO OPERATE THE PLAYER CORRECTLY AS INSTRUCTED.

THE FOLLOWING CAUTION LABEL IS LOCATED ON THE REAR PANEL OF THE PLAYER.

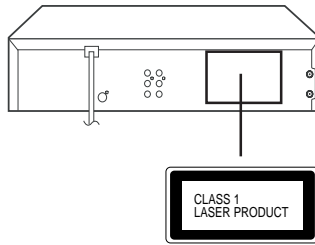

(Printed on the Rear Panel)

WHEN THIS PLAYER IS PLUGGED TO THE WALL OUTLET, DO NOT PLACE YOUR EYES CLOSE TO THE OPENING OF THE DISC TRAY AND OTHER OPENINGS TO LOOK INTO THE INSIDE OF THIS PLAYER.

USE OF CONTROLS OR ADJUSTMENTS OR PERFORMANCE OF PROCEDURES OTHER THAN THOSE SPECIFIED HEREIN MAY RESULT IN HAZARDOUS RADIATION EXPOSURE.

DO NOT OPEN COVERS AND DO NOT REPAIR YOURSELF. REFER SERVICING TO QUALIFIED PERSONNEL.

SERVICING NOTICES ON CHECKING

1. KEEP THE NOTICES

As for the places which need special attentions, they are indicated with the labels or seals on the cabinet, chassis and parts. Make sure to keep the indications and notices in the operation manual.

2. USE THE DESIGNATED PARTS

The parts in this equipment have the specific characters of incombustibility and withstand voltage for safety. Therefore, the part which is replaced should be used the part which has the same character.

Especially as to the important parts for safety which is indicated in the circuit diagram or the table of parts as a  mark, the designated parts must be used.

3. PUT PARTS AND WIRES IN THE ORIGINAL POSITION AFTER ASSEMBLING OR WIRING

There are parts which use the insulation material such as a tube or tape for safety, or which are assembled in the condition that these do not contact with the printed board. The inside wiring is designed not to get closer to the pyrogenic parts and high voltage parts. Therefore, put these parts in the original positions.

4. PERFORM A SAFETY CHECK AFTER SERVICING

Confirm that the screws, parts and wiring which were removed in order to service are put in the original positions, or whether there are the portions which are deteriorated around the serviced places serviced or not. Check the insulation between the antenna terminal or external metal and the AC cord plug blades. And be sure the safety of that.

HOW TO ORDER PARTS

Please include the following informations when you order parts. (Particularly the VERSION LETTER.)

1. MODEL NUMBER and VERSION LETTER.

The MODEL NUMBER can be found on the back of each product and the VERSION LETTER can be found at the end of the SERIAL NUMBER.

2. PART NO. and DESCRIPTION

You can find it in your SERVICE MANUAL.

WHEN REPLACING DVD DECK

[When the removal of the DVD Deck]

Before removing Pick Up PCB and DVD PCB connector, make the short circuit on the position as shown **Fig. 1** using a soldering. If you remove the DVD Deck with no soldering, the Laser may be damaged.

[When the installation of the DVD Deck]

Remove all the soldering on the short circuit position after the connection of Pick Up PCB and DVD PCB connector.

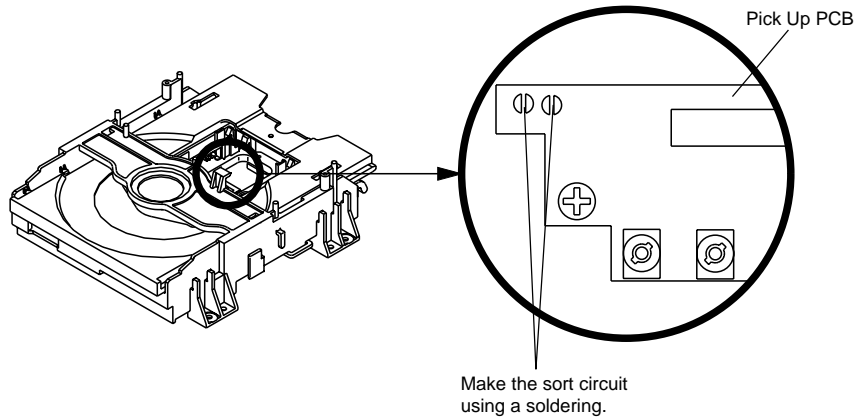

Fig. 1

PREPARATION OF SERVICING

The laser diode used for a pickup head may be destroyed with external static electricity. Moreover, even if it is operating normally after repair, when static electricity discharge is received at the time of repair, a life of product may become short. Please perform the following measure against static electricity, be careful of destruction of a laser diode enough at the time of repair, and work.

- It works on the desk which performed measures against static electricity, such as conductive mat.
- Soldering iron with ground wire or ceramic type is used.
- A worker needs to use a ground conductive wrist strap for body.

TAPE REMOVAL METHOD AT NO POWER SUPPLY

1. Remove the Top Cabinet, Front Cabinet and DVD Block. (Refer to item 1 of the **DISASSEMBLY INSTRUCTIONS.**)
2. Remove the screw ① of the Deck Chassis and remove the Loading Motor. (Refer to Fig. 2)
3. Rotate the Pinch Roller Cam in the direction of the arrow by hand to slacken the Video Tape.
4. Rotate the Clutch Ass'y either of the derections to wind the Video Tape in the Cassette Case.
5. Repeat the above step 3~4. Then take out the Video Cassette from the Deck Chassis. Be careful not to scratch on the tape.

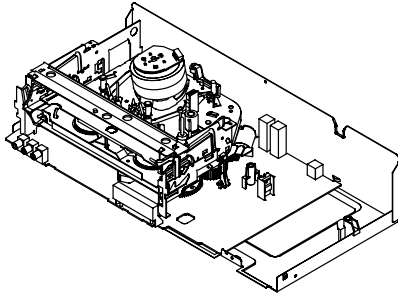

Fig. 1

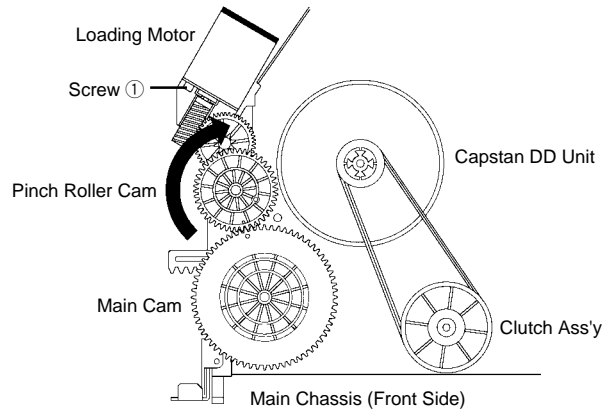

Fig. 2

DISC REMOVAL METHOD AT NO POWER SUPPLY

1. Remove the Back Cabinet and TV//DVD/VCR Block. (Refer to item 1 of the **DISASSEMBLY INSTRUCTIONS.**)
2. Rotate the Main Gear in the direction of the arrow by hand. (Refer to Fig. 1)
3. Draw the Tray.

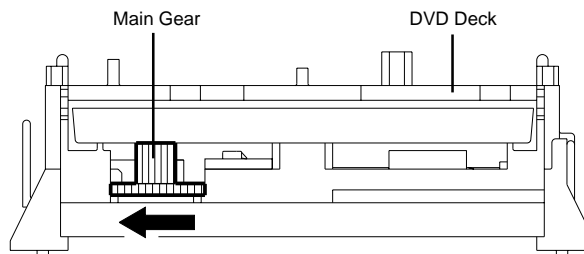

Fig. 1

PARENTAL CONTROL - RATING LEVEL 4 DIGIT PASSWORD CANCELLATION

If the stored 4 digit password in the Rating Level menu needs to be cancelled, please follow the steps below.

1. Turn Unit ON.
2. Press and hold the '7' key on the remote control unit.
3. Simultaneously press and hold the 'STOP' key on the front panel.
4. Hold both keys for more than 3 seconds.
5. The On Screen Display message 'PASSWORD CLEAR' will appear.
6. The 4 digit password has now been cleared

TABLE OF CONTENTS

IMPORTANT WARNING	A1-1
SERVICING NOTICES ON CHECKING	A1-1
HOW TO ORDER PARTS	A1-1
WHEN REPLACING DVD DECK	A1-2
PREPARATION OF SERVICING	A1-2
TAPE REMOVAL METHOD AT NO POWER SUPPLY	A1-3
DISC REMOVAL METHOD AT NO POWER SUPPLY	A1-3
PARENTAL CONTROL-RATING LEVEL	A1-3
TABLE OF CONTENTS	A2-1
GENERAL SPECIFICATIONS	A3-1~A3-6
DISASSEMBLY INSTRUCTIONS	
1. REMOVAL OF MECHANICAL PARTS AND P. C. BOARDS	B1-1~B2-3
2. REMOVAL OF VCR DECK PARTS	B2-1~B2-6
3. REMOVAL OF DVD DECK PARTS	B3-1~B3-3
4. REMOVAL AND INSTALLATION OF FLAT PACKAGE IC	B4-1, B4-2
KEY TO ABBREVIATIONS	C1-1, C1-2
SERVICE MODE LIST	C2-1
PREVENTIVE CHECKS AND SERVICE INTERVALS	C3-1, C3-2
WHEN REPLACING EEPROM (MEMORY) IC	C4-1
SERVICING FIXTURES AND TOOLS	D1-1
PREPARATION FOR SERVICING	D1-1
MECHANICAL ADJUSTMENTS	D2-1~D2-4
ELECTRICAL ADJUSTMENTS	D3-1, D3-2
BLOCK DIAGRAMS	
DVD	E-1, E-2
Y/C/AUDIO/CCD/HEAD AMP	E-3, E-4
SYSCON	E-5, E-6
OPERATION/DISPLAY	E-7, E-8
Hi-Fi/DEMODULATOR	E-9, E-10
TUNER/JACK	E-11, E-12
POWER	E-13, E-14
PRINTED CIRCUIT BOARDS	
DVD	F-1, F-2
VCR	F-3~F-6
OPERATION	F-7, F-8
SCHEMATIC DIAGRAMS	
MPEG/MICON/DSP	G-1, G-2
MEMORY	G-3, G-4
RF AMP/DSP	G-5, G-6
AUDIO/VIDEO	G-7, G-8
Y/C/AUDIO/CCD/HEAD AMP	G-9, G-10
SYSCON	G-11, G-12
TUNER/JACK	G-13, G-14
OPERATION/DISPLAY	G-15, G-16
Hi-Fi/DEMODULATOR	G-17, G-18
POWER	G-19, G-20
OPERATION 1	G-21, G-22
OPERATION 2	G-23, G-24
INTERCONNECTION DIAGRAM	G-25, G-26
WAVEFORMS	H-1~H-3
MECHANICAL EXPLODED VIEW	I1-1, I1-2
CHASSIS EXPLODED VIEWS	I2-1, I2-2
DVD DECK EXPLODED VIEWS	I3-1
MECHANICAL REPLACEMENT PARTS LIST	J1-1
CHASSIS REPLACEMENT PARTS LIST	J2-1
DVD DECK REPLACEMENT PARTS LIST	J3-1
ELECTRICAL REPLACEMENT PARTS LIST	J4-1, J4-2

GENERAL SPECIFICATIONS

G-1	Outline of the product		DVD VIDEO PLAYER & VHS Player / Recorder	
G-2	DVD System	Color System	NTSC	
		Disc	DVD, CD-DA, CD-R/RW	
		Disc Diameter	120 mm , 80 mm	
		Deck	Disc Loading System	
			Motor	Front Disc Loading
		Pick up		3 Motors
		Playback time (Max)	DVD 1-Layer	1-Lens 2-Beams System
			DVD 2-Layer	135min (4.7GB)
			CD	245min (8.5GB)
			VIDEO CD	74min --min
	Search speed	Actual	Fwd 4 steps 2-45 times (DVD) 4-40 times (CD)	
			Rev 4 steps 2-45 times (DVD) 4-40 times (CD)	
		Actual	Fwd 1/7-1/2 times	
			Rev --	
G-3	VCR System	System	VHS Player / Recorder	
		Video System	NTSC	
		Hi-Fi STEREO	Yes	
		NTSC PB(PAL60Hz)	No	
		Deck	DECK Loading System	OVD-7
			Motor	Front
		Heads	Video Head	3
			FM Audio Head	4Head
			Audio / Control	2Head
			Erase (Full Track Erase)	Mono/Yes
	Erase (Normal Audio Track Erase)	Yes		
	Tape Speed	Rec	PAL	
			NTSC	
		Play	PAL	
			NTSC	
		Fast Forward / Rewind Time (Approx.) at 25oC		-
			with Cassette	SP/SLP
		Forward/Reverse	NTSC or PAL-M	-
		Picture Search	PAL or SECAM	SP/LP/SLP
		Frame Advance		FF:4'50"/REW:2'30"
		Slow Speed		T-120
G-4	Tuning System	Broadcasting System	US System M	
		Tuner and	1Tuner	
		Receive CH	Destination	US (w/CATV)
			Tuning System	F-Synth
			Input Impedance	VHF/UHF 75 OHM
			CH Coverage	2-69,4A,A-5~ A-1,A-1, J~ W, W+1-W+84
		Intermediate	Picture (FP)	45.75 MHz
		Frequency	Sound (FS)	41.25 MHz
			FP-FS	4.50 MHz
		Preset CH		-
G-5	Power	Power Source	AC	
			DC	
		Power Consumption	Stand by	120V 60Hz
			Per Year	-
				18 W at 120V 60Hz
				2 W at 120V 60Hz
G-6	Regulation	Protector	Power Fuse	
			Safety Circuit	
			IC Protector (Micro Fuse)	
G-7	Temperature	Operation	5°C - 40°C	
		Storage	-20°C - 60°C	
			Less than 80% RH	
G-8	Operating Humidity			
G-9	Signal	Video Signal		
		Output Level	1 V p-p/75 ohm (DVD,VCR)	

GENERAL SPECIFICATIONS

		S/N Ratio (Weighted)	65 dB(DVD) 50 dB(VCR)
	RGB Signal	Horizontal Resolution	500 Lines (DVI 230 Lines(VCR Mode)
		Output Level	-
	Audio Signal	Input Level Microphone	-
		Input Level Line	-
		Output Level Line	-8 dBm/ 1k ohm (VCR, 0dBm=0.775Vrms) -12dBm/ 1k ohm (DVD, -20dBfs 0dBfs=2.0Vrms)
		Digital Output Level	0.5 V p-p / 75 ohm(DVD)
		S/N Ratio at (Weighted)	90dB(DVD), 42dB(VCR at SP)
		Harmonic Distortion (1KHz) Typical	0.02% (1KHz) (DVD) , 1.5% (1KHz) (VCR)
		Frequency Response : DVD Mode at DVD	4 Hz - 22 KHz
		DVD Mode at VIDEO CD	-
		DVD Mode at CD	4 Hz - 20 KHz
		VCR Mode at SP	100Hz - 10 KHz
		VCR Mode at LP	-
		VCR Mode at SLP	100Hz - 4 KHz
	Hi-Fi Audio Signal	Dynamic Range : More than	90dB
		Frequency Response	20Hz ~20kHz
		Wow And Flutter : Less than	0.01 %Wrms
		Channel Separation : More than	60 dB
		Harmonic Distortion : Less than	0.01
G-10	On Screen Display (DVD)	Menu	Yes
		Menu Type	Character
		Language	Yes
		Menu	Yes
		Subtitle	Yes
		Audio	Yes
		Picture	Yes
		TV Screen Size	Yes
		OSD Display On/Off	Yes
		JPEG Interval	No
		Select Files	No
		E.B.L. (Enhanced Black Level)	No
		Sound	Yes
		DRC (Dynamic Range Control)	Yes
		Dialogue On:DRC(TV)/ Off:DRC(Std)	No
		dts Decode	No
		Output (5.1ch/2ch)	No
		Surround On/Off	No
		Center On/Off	No
		Sub Woofer On/Off	No
		Parental	Yes
		Password Lock/Unlock	Yes
		Rating Level	Yes
		Other	Yes
		OSD Language (Set up Language)	Yes
		Output (RGB / Composite)	No
		Open	Yes
		Close	Yes
		No disc	Yes
		Reading	Yes
		Play	Yes
		Still/Pause	Yes
		Stop	Yes
		Prohibit Mark	Yes
		Step	Yes
		Skip (>>)	Yes
		Skip (<<)	Yes
		Random	Yes (CD)
		Repeat	Yes
		Slow+	Yes
		Slow-	No
		Search+	Yes
		Search-	Yes
		Jump	Yes
		Resume	Yes
		Title No.	Yes
		Chapter No.	Yes
		Track No.	Yes
		Time	Yes
		Subtitle No.	Yes
		Angle No.	Yes
		Vocal On/Off	Yes
		Audio No.	Yes
		Audio Stereo L/R	No

GENERAL SPECIFICATIONS

		Zoom	Yes
		Marker No.	Yes
		Spatializer (N-2-2)	No
		Program Play Back	Yes (CD)
		MP3/WMA/JF	
		Folder Name	No
		File Name	No
		File No	No
		Time	No
		Track No	No
		Progressive Scan Out ON/OFF	No
	On Screen Display(VCR)	Menu	Yes
		Menu Type	Character
		Timer Rec Set	Yes
		Auto Repeat On/Off	Yes
		SAP On/Off	Yes
		CH Set-Up	Yes
		TV/CABLE	Yes
		Auto CH Memory	Yes
		Add/Delete	Yes
		System Set Up	Yes
		Clock Set	Yes (Calendar 12H)
		Language	Yes
		No Noise Back Ground	Yes
		Auto Clock	Yes
		Standard Time	Yes
		Daylight Saving Time	Yes
		G-CODE(or SHOWVIEW or PLUSCODE)No. Entry	No
		Stereo, Audio Output, SAP	Yes
		Play/Stop/FF/Rew/Rec/OTR/Pause/Eject/Tape In/Repeat (Symbol Mark)	Yes
		CH	Yes
		Clock	Yes
		Repeat	Yes
		Tape Counter	Yes
		Index	Yes
		Tape Speed	Yes
		ATR / Manual Tracking	Yes
		ZERO Return	Yes
		Hi-Fi	Yes
G-11	OSD Language	DVD OSD	English / French / Spanish
		VCR OSD	English / French / Spanish
G-12	Clock,Timer and Timer Back-up	Calendar	1990/1/1 ~ 2081/12/31
		Timer Events	8 Program/ 1 Month
		One Touch Recording Max Time	6 Hours
		OTPB Valid Time	No
		Timer Back-up (at Power Off Mode)	5sec
G-13	Display	DISPLAY	No
		DISPLAY type	--
		Clock/Counter,CH,Timer Rec,OTR, Play Rec,FF(Cue),Rew(Rev),Stop,ATR,Eject	--
		VCR	--
		DVD	--
		CD	--
		Clock	--
		AM	
		PM	
		Counter	VCR
			DVD
			CD
		Eject	--
		Counter Remain	--
		Play	--
		Stop	--
		Rec	--
		FF / Cue	--
		REW / Review	--
		Pause / Still	--
		OTR (ITR)	--
		T-Rec	--
		Chapter	--
		TITLE	--
		TRACK	--
		Repeat	--
		Hi-Fi	--
		SP	--
		LP	--
		SLP	--

GENERAL SPECIFICATIONS

		CH	--	
		RF Output CH	--	
		Tape In	--	
		Remocon Custom Code	--	
		Progressive Scan Out	--	
G-14	Remote Control	Unit	RC-JT	
		Glow in Dark Remocon	No	
		Format	NEC	
		Custom Code	71-8E	
		Power Source	Voltage(D.C) UM size x pcs	3V UM-4 x 2 pcs
		Total Keys		44 Keys
		Keys	Power	Yes
			DISPLAY/CALL	Yes
			1	Yes
			2	Yes
			3	Yes
			4	Yes
			5	Yes
			6	Yes
			7	Yes
			8	Yes
			9	Yes
			0	Yes
			Input Select	No
			Input Select / PROGRESSIVE	No
			UP/CH+	Yes
			DOWN/CH-	Yes
			LEFT/ SET- / TRACKING-	Yes
			RIGHT/ SET+ / TRACKING+	Yes
			VCR/DVD	Yes
			TV/VCR	Yes
			DVD MENU	Yes
			TITLE	Yes
			SETUP MENU/VCR MENU	Yes
			SELECT/ENTER	Yes
			CLEAR/CANCEL	Yes
			RETURN	Yes
			PLAY	Yes
			STOP	Yes
			PAUSE/STILL/STEP	Yes
			FF(Cue)/SEARCH+	Yes
			REW(Review)/SEARCH-	Yes
			REC/OTR	Yes
			SKIP+ / INDEX+	Yes
			SKIP- / INDEX-	Yes
		AUDIO / AUDIO SELECT	Yes	
		ANGLE/COUNTER RESET	Yes	
		SUBTITLE/ATR	Yes	
PLAY MODE/SPEED	Yes			
T-REC	Yes			
CLOCK / COUNTER	No			
JUMP/ZERO RETURN	Yes			
ZOOM	Yes			
REPEAT A-B	Yes			
SLOW (Forward)	Yes			
MARKER	Yes			
OPEN/CLOSE	Yes			
EJECT	Yes			
G-15	Features (DVD)	Auto Power Off	No	
		Parental Lock	Yes	
		Video CD Playback	No	
		MP3 Playback	No	
		WMA Playback	No	
		JPEG Playback	No	
		Progressive Scan Out	No	
		Digital Out	Dolby Digital	Yes
			MPEG	Yes
			PCM	Yes
			DTS	No
		Down Mix Out	(Dolby Digital)	Yes
			(DTS)	No
		Spatializer (N-2-2)	No	
		Screen Saver	Yes	
Tray Lock	No			
Auto Stop	No			
Audio DAC	192kHz / 24bit			

GENERAL SPECIFICATIONS

	Features (VCR)	Auto Head Cleaning	Yes			
		Auto Tracking	Yes			
		HQ (VHS Standard High Quality)	Yes			
		Auto Power On, Auto Play, Auto Rewind, Auto Eject	Yes			
		Auto Power Off	No			
		Forward/Reverse Picture Search	Yes			
		VIDEO PLUS+ (SHOWVIEW, G-CODE)	No			
		One Touch Playback	No			
		Auto CH Memory	Yes			
		AREA CODE	No			
		Auto Clock Set	Yes			
		Index Search	Yes			
		SQPB	No			
		CATV	Yes			
		Energy Star	No			
		MTS (SAP)	Yes			
		CM Skip (30sec x 6 Times)	No			
Copy (Disc to Tape)	No					
G-16	Accessories	Owner's Manual	Language w/Guarantee Card	English , French		
				No		
		Remote Control Unit		Yes		
		Guarantee Card		Yes		
		Registration Card		No		
		Warning Sheet		No		
		Service Station List		No		
		Important Tag		No		
		AC Plug Adapter		No		
		Quick Set-up Sheet		No		
		Battery		No		
			UM size x pcs	--		
		AC Cord		No		
		AV Cord (1.2m)		Yes		
		75 Ohm Coaxial Cable (0.9m)		Yes		
		S-Video Cable		No		
		21pin cable		No		
		800 No Sticker		No		
		Toll Free Insert Sheet		No		
		Safety Tip		No		
		Printed Matter for Disney		Yes		
		G-17	Interface	Switch	Front	Power
Play	Yes					
Eject (VCR)	Yes					
Stop	Yes					
Rec/OTR	Yes					
Open/Close (DVD)	Yes					
CH +	Yes					
CH -	Yes					
FF/ Search(>>)	Yes					
Rew/Search(<<)	Yes					
Still/Pause	No					
Shuttle (Search/REV/FWD)	No					
DVD/VCR	Yes					
Main Power SW				No		
	Rear			Attenuator	No	
				S-Video/Component Video Selector	No	
				RF Out (Slide SW)	No	
Volume				No		
	Phones Volume			No		
	Mic Volume			No		
	Echo Volume			No		
Terminals	Front			Video In	No	
				Audio In	No	
	Rear			Video Output	RCA x1 (Yellow) S-Video x 1 (DVD Signal Only)	
				Audio Output	RCA x 4 (Stereo, White/Red) Coaxial x 1 (Digital Audio,DVD Signal Only)	
				Optical Out (Option)	No	
				Video Input (Option)	No	
				Audio Input (Option)	No	
				RF Input / Output	Yes	
				Euro Scart	No	
				AC Inlet	No	
				Indicator	LED	Power
	Rec					Yes (RED)
	T-Rec					Yes (RED)

GENERAL SPECIFICATIONS

		TV/VCR	Yes (RED)
		DVD	Yes (RED)
		VCR	Yes (RED)
		Surround	No
		Level Meter	No
G-18	Set Size	Approx. W x D x H (mm)	497.5 x 295 x 149.5
G-19	Weight	Net (Approx.)	4.5 kg(9.9lbs)
		Gross (Approx.)	6.0 kg(13.2lbs)
G-20	Carton	Master Carton	No
		Content	--- Sets
		Material	--- / ---
		Dimensions W x D x H(mm)	---
		Description of Origin	---
		Gift Box	Yes
		Material	Single / Full Color
		W/Color Photo Label	No
		Dimensions W x D x H(mm)	565 x 408 x 231
		Design	As Per BUYER 's
		Description of Origin	Yes
		Drop Test	Natural Dropping At 1 Corner / 3 Edges / 6 Surfaces
		Height (cm)	80 cm
		Container Stuffing	1,160 Sets/40' container
G-21	Material	Cabinet	Front
			Top
			Bottom
		PCB	Non-Halogen Demand
			Eyelet Demand
G-22	Environment	Pb Free	Lead-free Solder
			Other
		Cd Free	

DISASSEMBLY INSTRUCTIONS

1. REMOVAL OF MECHANICAL PARTS AND P.C. BOARDS

1-1: TOP CABINET/FRONT CABINET/ OPERATION 1/2 PCB/LEG, CLASSIC (L,R) (Refer to Fig. 1-1)

1. Remove the 2 screws ①.
2. Remove the LEG, Classic (L,R) Ass'y in the direction of arrow (A).
3. Remove the screw ②.
4. Remove the Top Cabinet in the direction of arrow (B).
5. Remove the 5 screws ③.
6. Remove the Top Cabinet in the direction of arrow (C).
7. Disconnect the following connector: (CP680 and CP682).
8. Unlock the 9 supports ④.
9. Remove the Front Cabinet in the direction of arrow (D).
10. Remove the 9 screws ⑤.
11. Remove the Operation 1/2 PCB in the direction of arrow (E).

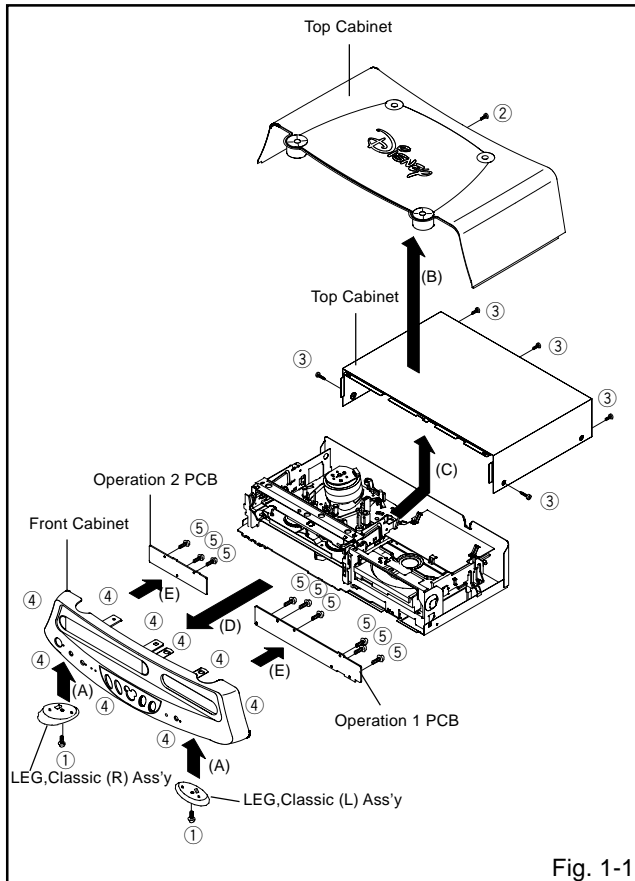

1-2: FLAP (Refer to Fig. 1-2)

1. Open Flap to 90° and flex in direction of arrow (A), at the same time slide in direction of arrow (B).
2. Then lift in direction of arrow (C).

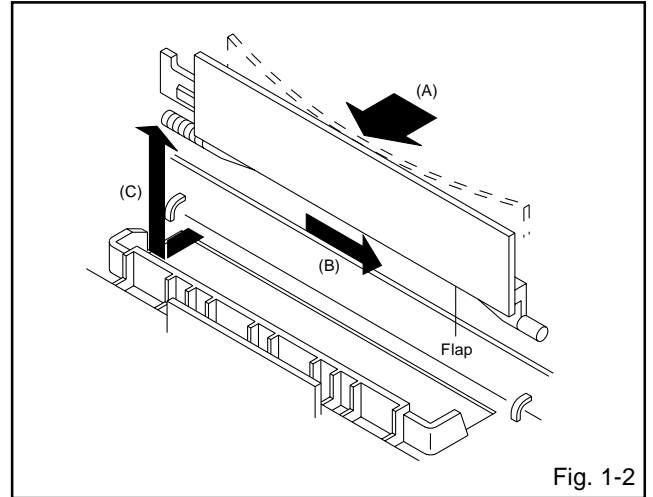

DISASSEMBLY INSTRUCTIONS

1-3: DVD DECK/DVD PCB (Refer to Fig. 1-3)

1. Make the short circuit on the position as shown Fig. 1-3 using a soldering. If you remove the DVD Deck with no soldering, the Laser may be damaged.
2. Unlock the support ① and remove the Deck Top Holder in the direction of arrow (A).
3. Remove the 2 screws ②.
4. Remove the 2 screws ③.
5. Disconnect the following connectors: (CP501, CP8001).
6. Remove the DVD Deck in the direction of arrow (B).
7. Remove the 2 screws ④.
8. Disconnect the following connectors: (CP2601, CP2602 and CP2603).
9. Remove the DVD PCB in the direction of arrow (C).
10. Remove the 3 screws ⑤.
11. Remove the Front Angle in the direction of arrow (D).

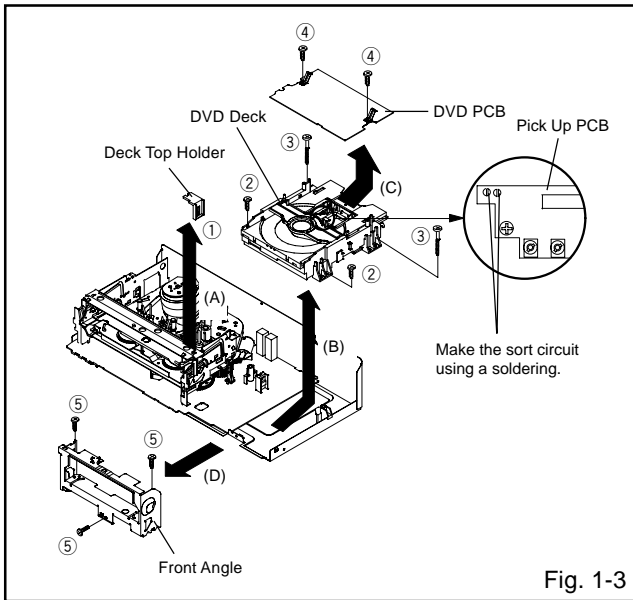

Fig. 1-3

NOTE

When the installation of the DVD Deck, remove all the soldering on the short circuit position after the connection of Pick Up PCB and VCR PCB connector.

1-4: VCR DECK (Refer to Fig. 1-4)

NOTE

Do not remove the cable at the FE Head section. The FE Head may be damaged if you remove the cable by force.

1. Remove the screw ①.
2. Remove the FE Head.
3. Move the Cassette Holder Ass'y to the back side.
4. Remove the 2 screws ②.
5. Remove the 2 screws ③.
6. Disconnect the following connectors: (CP101, CP102, CP103 and CP3001).
7. Remove the VCR Deck in the direction of arrow.

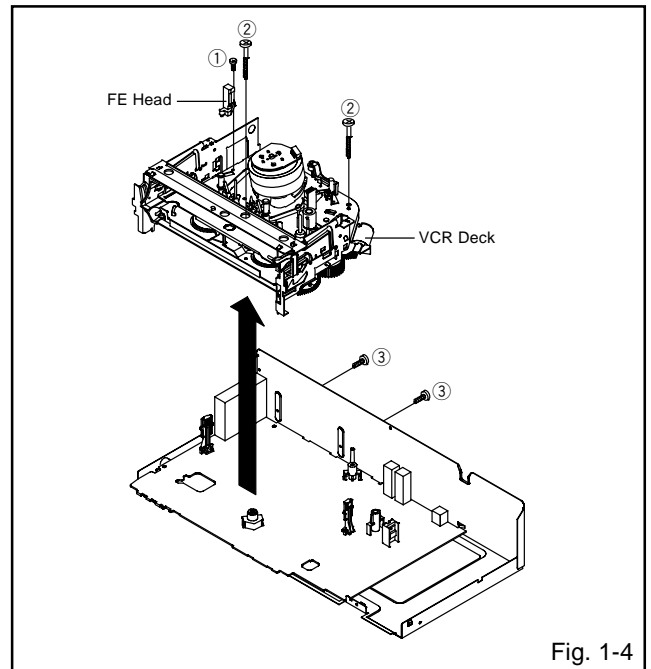

Fig. 1-4

1-5: VCR PCB (Refer to Fig. 1-5)

1. Remove the screw ①.
2. Remove the 3 screws ②.
3. Remove the screw ③.
4. Remove the VCR PCB in the direction of arrow.

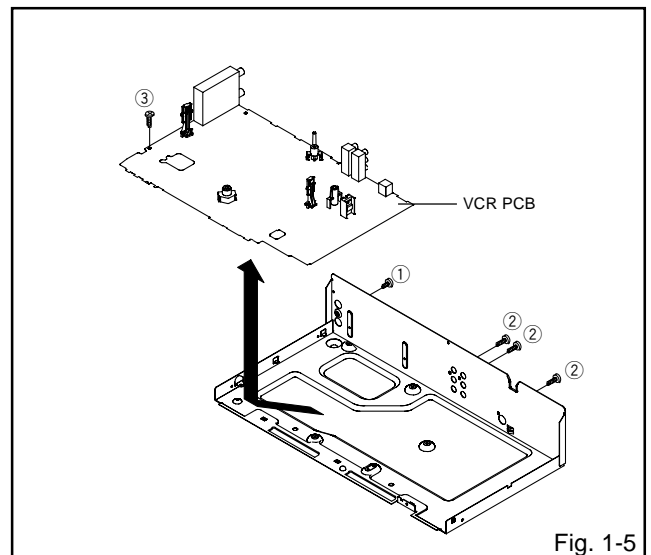
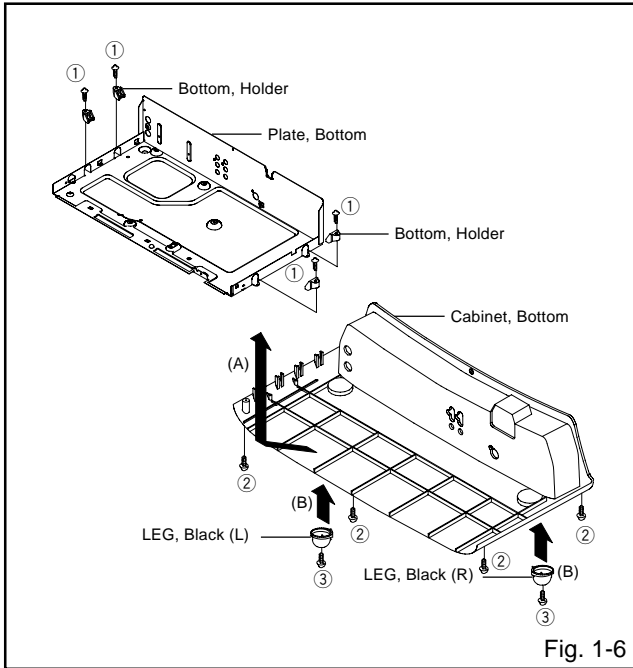

Fig. 1-5

DISASSEMBLY INSTRUCTIONS

1-6: PLATE, BOTTOM/CABINET BOTTOM/ LEG, BACK (L,R) (Refer to Fig. 1-6)

1. Remove the 4 screw ①.
2. Remove the Bottom, Holder.
3. Remove the Plate, Bottom in the direction of arrow (A).
4. Remove the 4 screws ②.
5. Remove the 2 screws ③.
6. Remove the Cabinet, Bottom and LEG, Black (L,R) in the direction of arrow (B).



DISASSEMBLY INSTRUCTIONS

2. REMOVAL OF VCR DECK PARTS

2-1: TOP BRACKET (Refer to Fig. 2-1)

1. Extend the 2 supports ①.
2. Slide the 2 supports ② and remove the Top Bracket.

NOTE

1. After the installation of the Top Bracket, bend the support ① so that the Top Bracket is fixed.

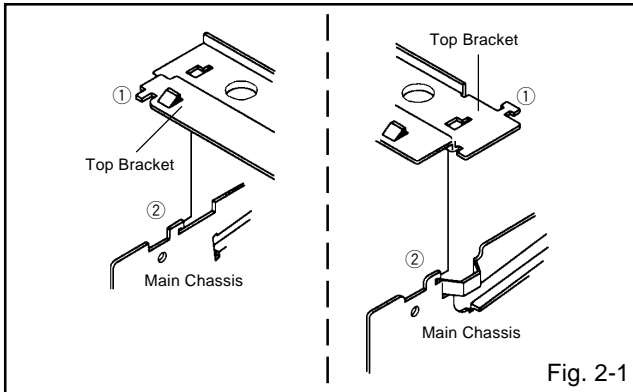

2-2: CASSETTE HOLDER ASS'Y (Refer to Fig. 2-2)

1. Move the Cassette Holder Ass'y to the front side.
2. Push the Locker R to remove the Cassette Side R.
3. Remove the Cassette Side L.

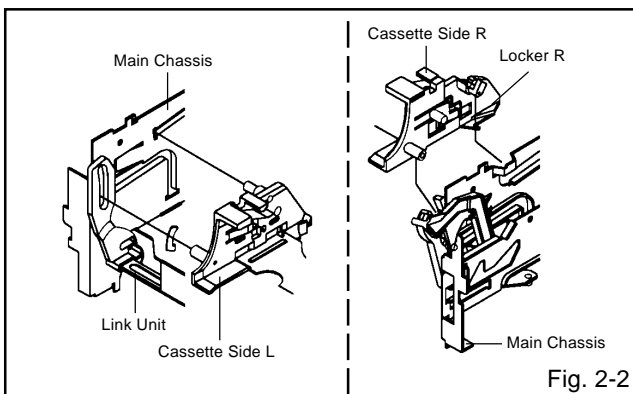

2-3: CASSETTE SIDE L/R (Refer to Fig. 2-3-A)

1. Remove the Locker Spring.
2. Unlock the 4 supports ① and then remove the Cassette Side L/R.
3. Unlock the support ② and then remove the Locker R.

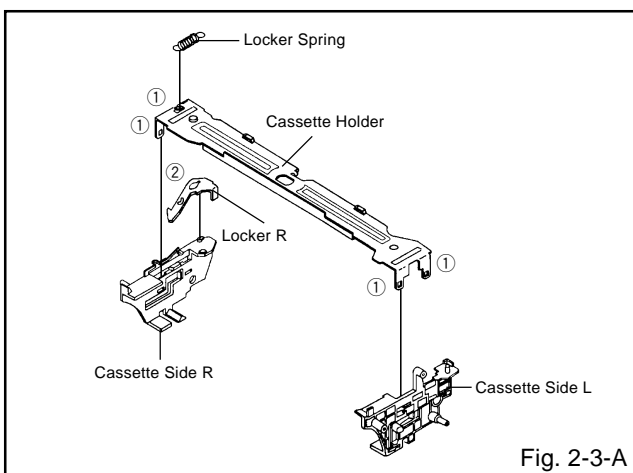

NOTE

1. In case of the Locker R installation, check if the one position of Fig.2-3-B are correctly locked.
2. When you install the Cassette Side R, be sure to move the Locker R after installing.

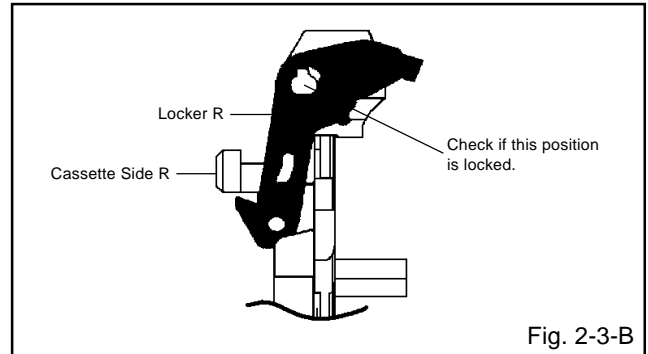

2-4: LINK UNIT (Refer to Fig. 2-4)

1. Set the Link Unit to the Eject position.
2. Unlock the support ①.
3. Remove the (A) side of the Link Unit first, then remove the (B) side.

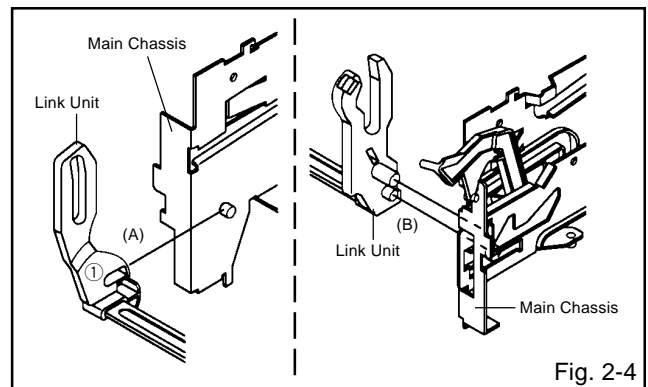

2-5: LINK LEVER/FLAP LEVER (Refer to Fig. 2-5)

1. Extend the support ①.
2. Remove the Link Lever.
3. Remove the Flap Lever.

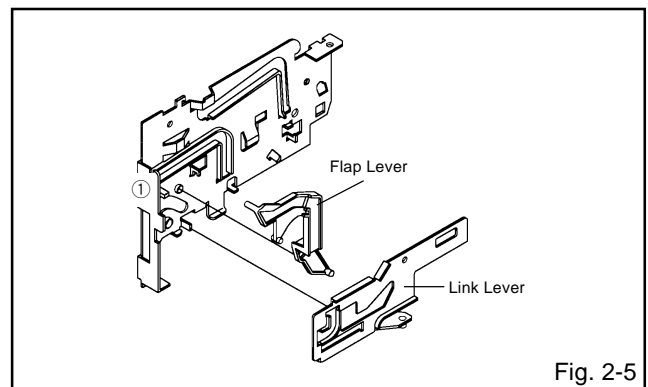

DISASSEMBLY INSTRUCTIONS

2-6: LOADING MOTOR/WORM (Refer to Fig. 2-6-A)

1. Remove the screw ①.
2. Remove the Loading Motor.
3. Remove the Worm.

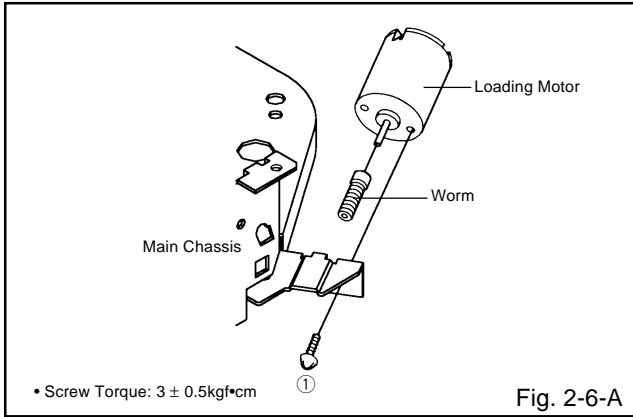

NOTE

1. In case of the Worm installation, check if the value of the Fig. 2-6-B is correct.
2. In case of the Loading Motor installation, hook the wire on the Cassette Opener as shown Fig. 2-6-C.
3. When installing the wires between Capstan DD Unit and Loading Motor, connect them correctly as shown Fig. 2-6-D.

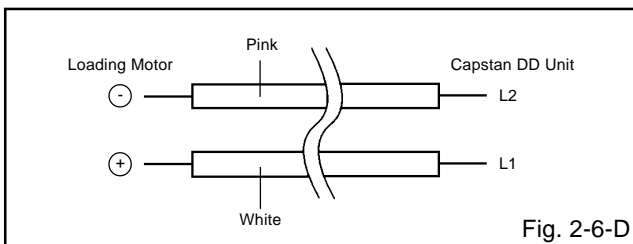
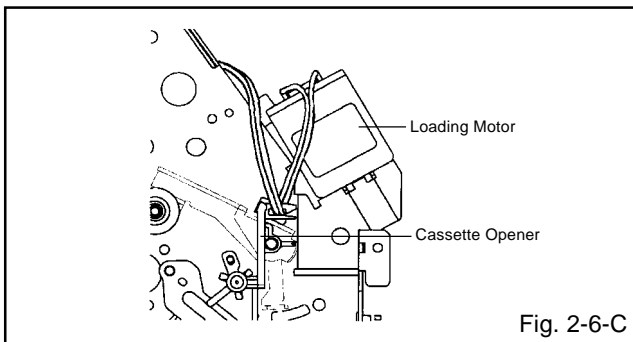
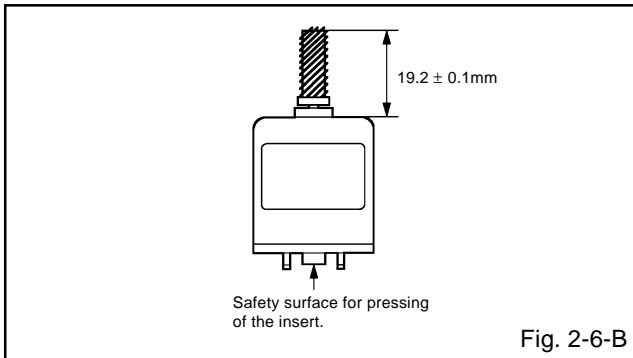

2-7: TENSION ASS'Y (Refer to Fig. 2-7-B)

1. Turn the Pinch Roller Cam clockwise so that the Tension Holder hook is set to the position of Fig. 2-7-A to move the Tension Arm Ass'y.
2. Remove the Tension Spring.
3. Unlock the 2 supports ① and remove the Tension Band.
4. Unlock the support ② and remove the Tension Arm Ass'y.
5. Unlock the support ③ and remove the Tension Connect.
6. Float the hook ④ and turn it clockwise then remove the Tension Holder.

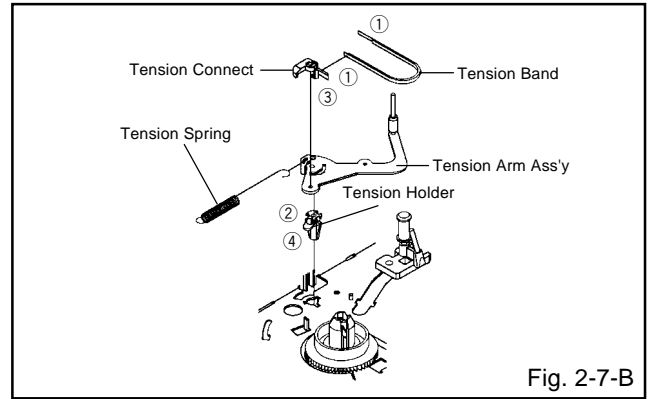
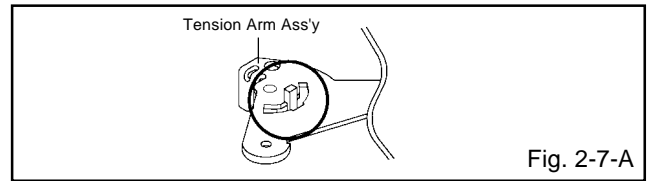

NOTE

1. In case of the Tension Band installation, note the direction of the installation. (Refer to Fig. 2-7-C)
2. In case of the Tension Band installation, install correctly as Fig. 2-7-D.
3. In case of the Tension Connect installation, install as the circled section of Fig. 2-7-E.

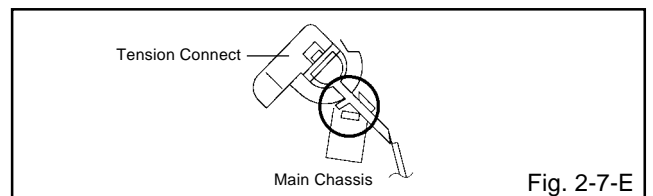
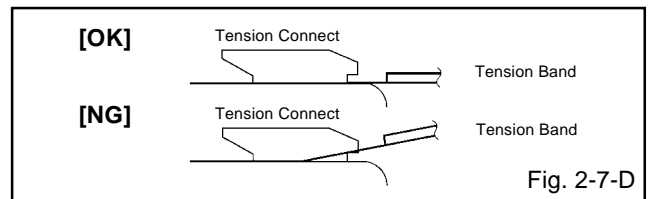
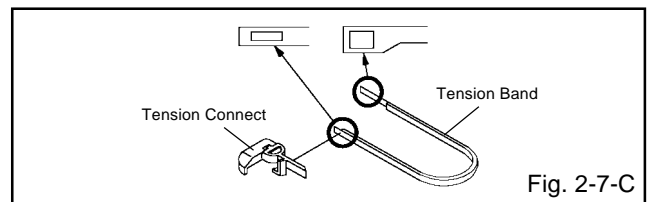

DISASSEMBLY INSTRUCTIONS

2-8: T BRAKE ARM/T BRAKE BAND (Refer to Fig. 2-8-A)

1. Remove the T Brake Spring.
2. Turn the T Brake Arm clockwise and bend the hook section to remove it.
3. Unlock the 2 supports ① and remove the T Brake Band.

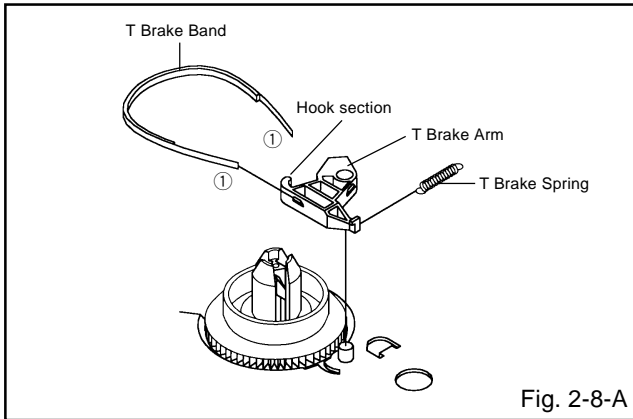

Fig. 2-8-A

NOTE

1. In case of the T Brake Band installation, install correctly as Fig. 2-8-B.

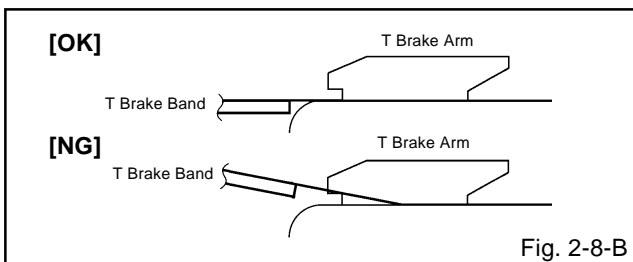

Fig. 2-8-B

2-9: S REEL/T REEL/IDLER ARM ASS'Y/IDLER GEAR (Refer to Fig. 2-9-A)

1. Remove the S Reel and T Reel.
2. Remove the 2 Polyslider Washers ①.
3. Remove the Idler Arm Ass'y and Idler Gear.

NOTE

1. Take care not to damage the gears of the S Reel and T Reel.
2. The Polyslider Washer may be remained on the back of the reel.
3. Take care not to damage the shaft.
4. Do not touch the section "A" of S Reel and T Reel. (Use gloves.) (Refer to Fig. 2-9-A) Do not adhere the stains on it.
5. When you install the reel, clean the shaft and grease it (FG-84M). (If you do not grease, noise may be heard in FF/REW mode.)
6. After installing the reel, adjust the height of the reel. (Refer to MECHANICAL ADJUSTMENT)

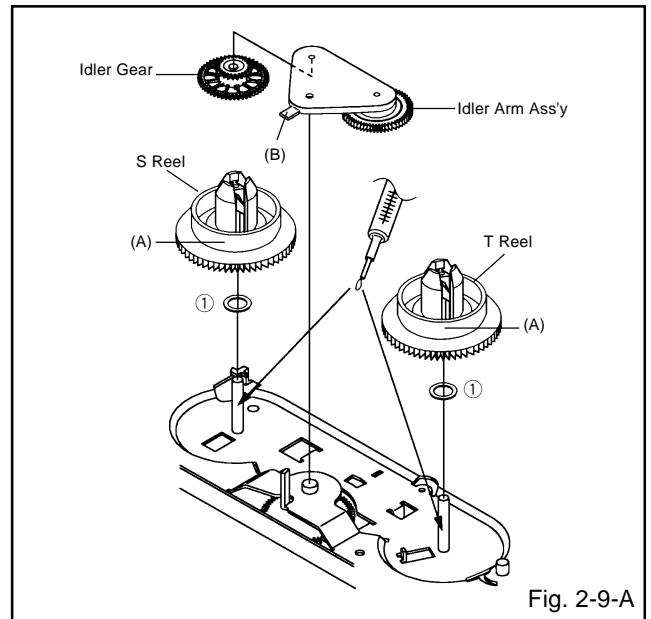

Fig. 2-9-A

NOTE

1. In case of the S Reel and T Reel installation, check if the correct parts are installed. (Refer to Fig. 2-9-B)
2. In case of the Idler Arm Ass'y installation, install correctly as Fig. 2-9-C. And also set it so that the section "B" of Fig. 2-9-A is placed under the Main Chassis tab.

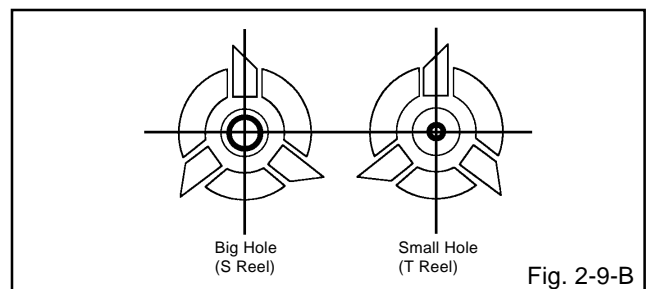

Fig. 2-9-B

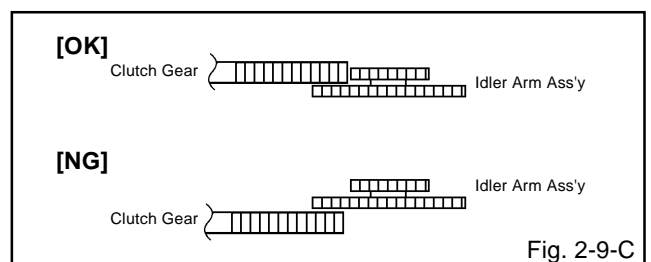
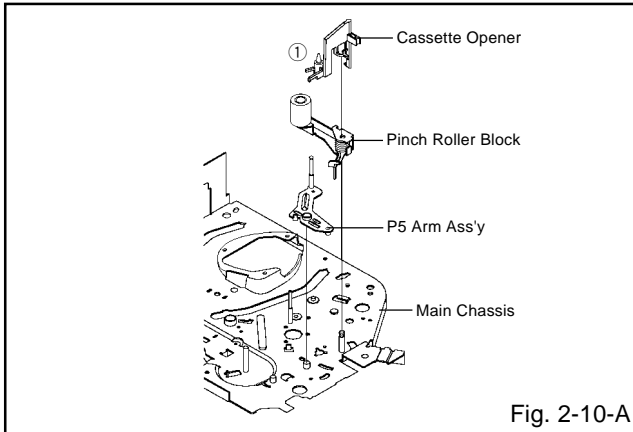

Fig. 2-9-C

DISASSEMBLY INSTRUCTIONS

2-10: CASSETTE OPENER/PINCH ROLLER BLOCK/ P5 ARM ASS'Y (Refer to Fig. 2-10-A)

1. Unlock the support ① and remove the Cassette Opener.
2. Remove the Pinch Roller Block and P5 Arm Ass'y.



NOTE

1. Do not touch the Pinch Roller. (Use gloves.)
2. In case of the Pinch Roller Block and the Pinch Roller Cam installation, install correctly as Fig. 2-10-B.

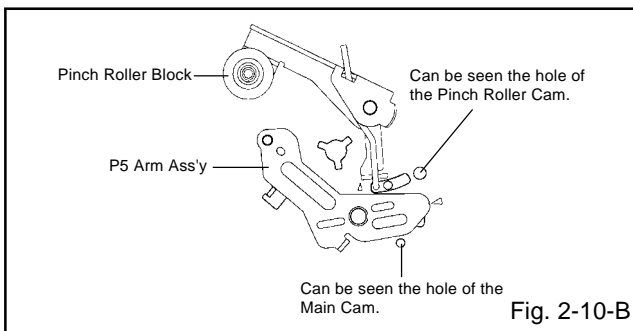

2-11: A/C HEAD (Refer to Fig. 2-11-A)

1. Remove the screw ①.
2. Remove the A/C Head Base.
3. Remove the 3 screws ②.
4. Remove the A/C Head and A/C Head Spring.

NOTE

1. Do not touch the A/C Head. (Use gloves.)
2. When you install the A/C Head Spring, install as shown in Fig. 2-11-B.
3. When you install the A/C Head, tighten the screw (1) first, then tighten the screw (2), finally tighten the screw (3).

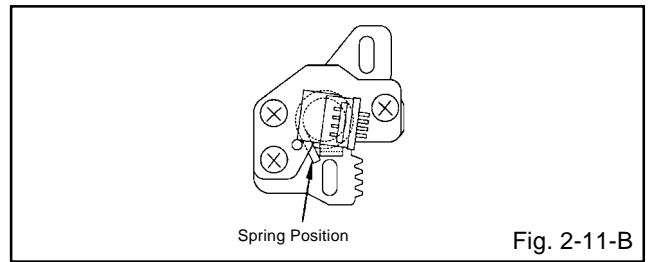
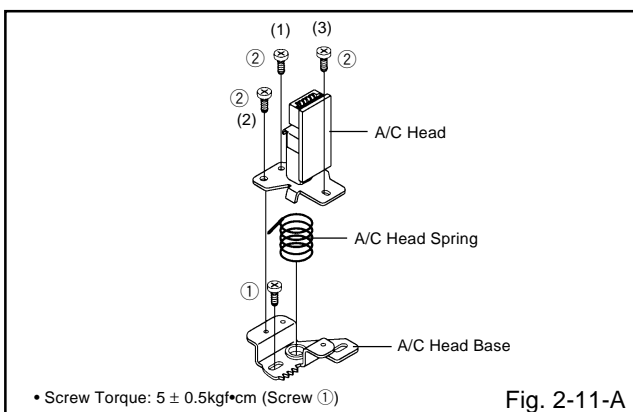

2-12: FE HEAD (RECORDER ONLY) (Refer to Fig. 2-12)

1. Remove the screw ①.
2. Remove the FE Head.

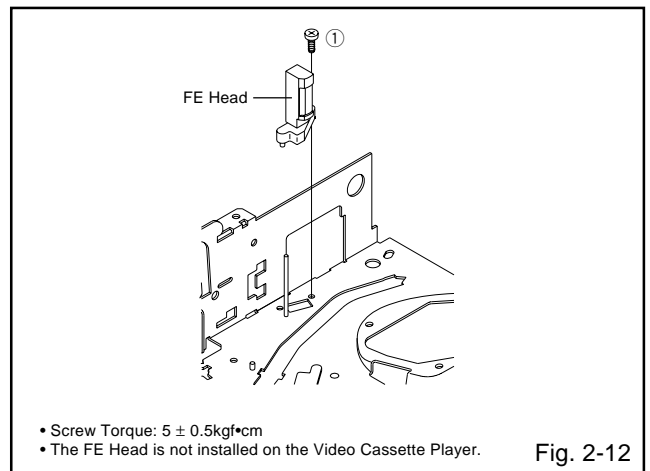

2-13: AHC ASS'Y/CYLINDER UNIT ASS'Y (Refer to Fig. 2-13)

1. Unlock the support ① and remove the AHC Ass'y.
2. Disconnect the following connector:
(CD2001)
3. Remove the 3 screws ②.
4. Remove the Cylinder Unit Ass'y.

NOTE

1. When you install the Cylinder Unit Ass'y, tighten the screws from (1) to (3) in order while pulling the Ass'y toward the left front direction.

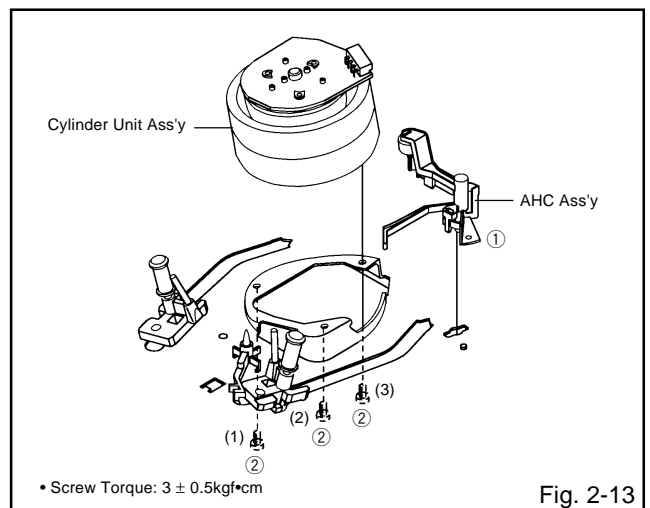

DISASSEMBLY INSTRUCTIONS

2-14: CAPSTAN DD UNIT (Refer to Fig. 2-14)

1. Remove the Capstan Belt.
2. Remove the screw ①.
3. Remove the Capstan Holder.
4. Remove the 3 screws ②.
5. Remove the Capstan DD Unit.

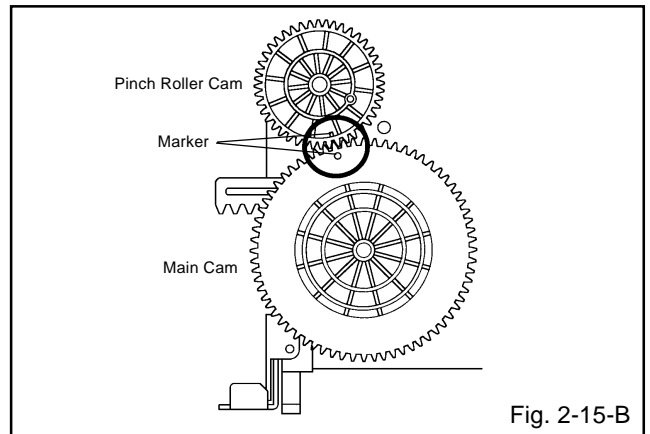
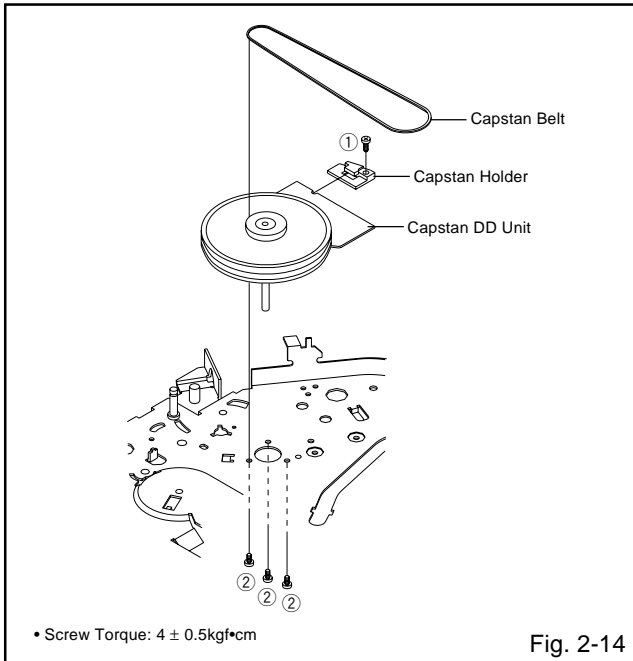

2-16: LOADING GEAR S/T UNIT (Refer to Fig. 2-16-A)

1. Remove the E-Ring ① and remove the Main Loading Gear.
2. Remove the Main Rod, Tension Lever, Loading Arm S Unit and Loading Arm T Unit.

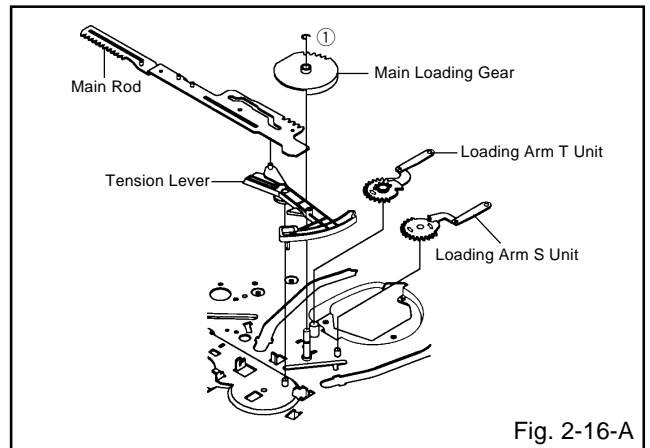

2-15: MAIN CAM/PINCH ROLLER CAM/JOINT GEAR (Refer to Fig. 2-15-A)

1. Remove the E-Ring ①, then remove the Main Cam.
2. Remove the E-Ring ②, then remove the Pinch Roller Cam and Joint Gear.

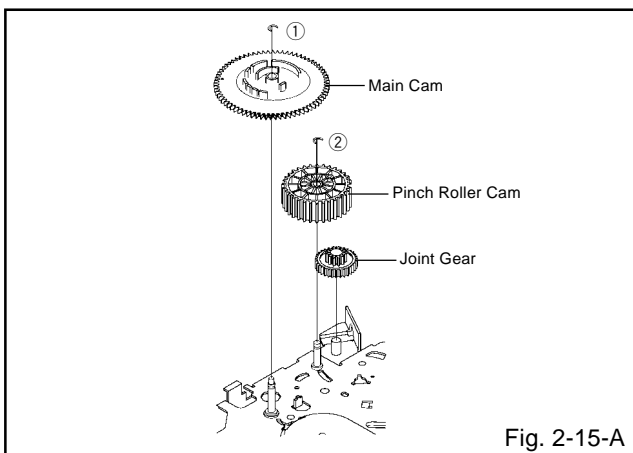

NOTE

1. When you install the Loading Arm S Unit, Loading Arm T Unit and Main Loading Gear, align each marker. (Refer to Fig. 2-16-B)

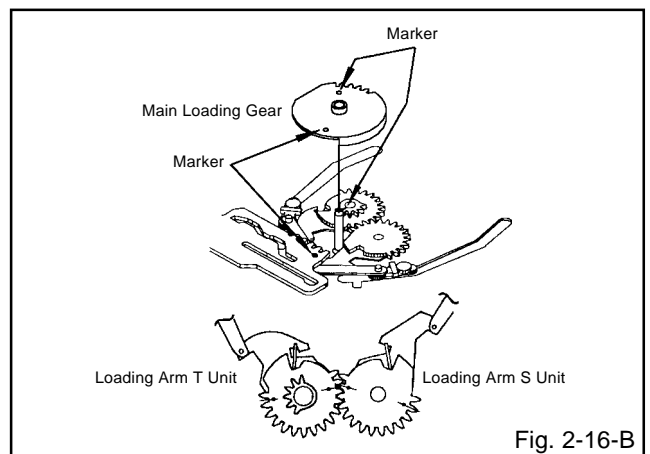

NOTE

1. In case of the Pinch Roller Cam and Main Cam installation, install them as the circled section of Fig. 2-15-B so that the each markers are met. (Refer to Fig. 2-15-B)

DISASSEMBLY INSTRUCTIONS

2-17: CLUTCH ASS'Y/RING SPRING/CLUTCH LEVER/ CLUTCH GEAR (Refer to Fig. 2-17-A)

1. Remove the Polyslider Washer ①.
2. Remove the Clutch Ass'y and Ring Spring.
3. Remove the Clutch Lever.
4. Remove the Coupling Gear, Coupling Spring and Clutch Gear.

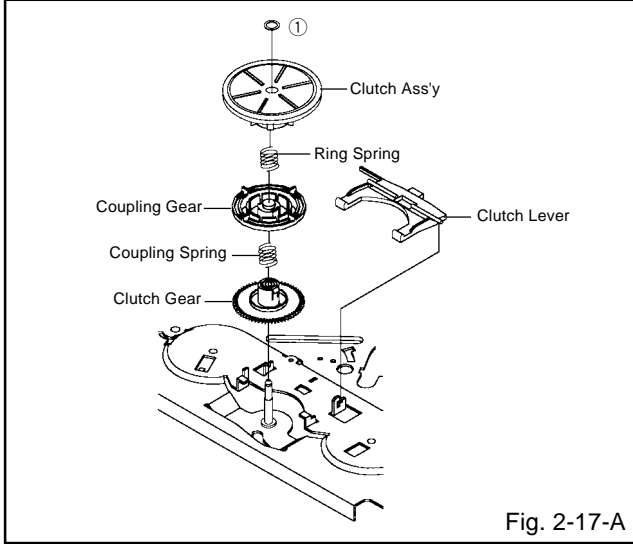

Fig. 2-17-A

NOTE

1. In case of the Clutch Ass'y installation, install it with inserting the spring of the Clutch Ass'y into the dent of the Coupling Gear. (Refer to Fig. 2-17-B)

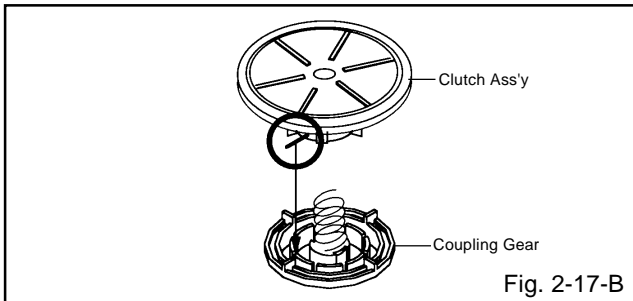

Fig. 2-17-B

2-18: CASSETTE GUIDE POST/INCLINED BASE S/T UNIT/P4 CAP/LED REFLECTOR (Refer to Fig. 2-18-A)

1. Remove the P4 Cap.
2. Unlock the support ① and remove the Cassette Guide Post.
3. Remove the Inclined Base S/T Unit.
4. Remove the screw ②.
5. Remove the LED Reflector.

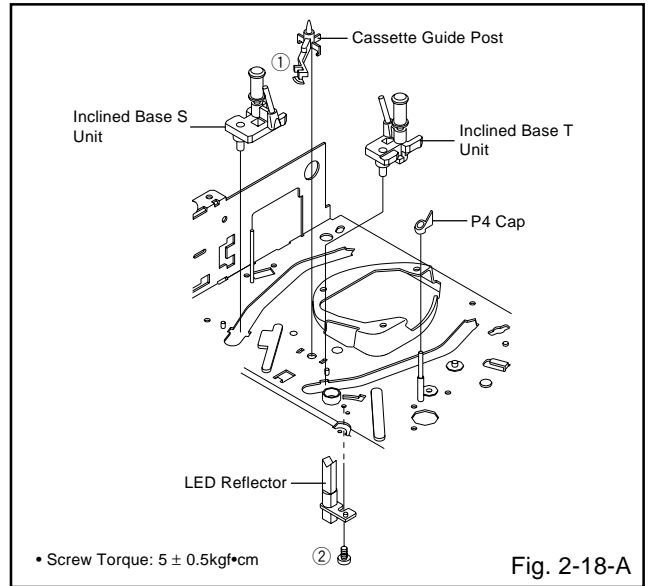

Fig. 2-18-A

NOTE

1. Do not touch the roller of Guide Roller.
2. In case of the P4 Cap installation, install it with parallel for "A" and "B" of Fig. 2-18-B.
3. In case of the Cassette Guide Post installation, install correctly as the circled section of Fig. 2-18-C.

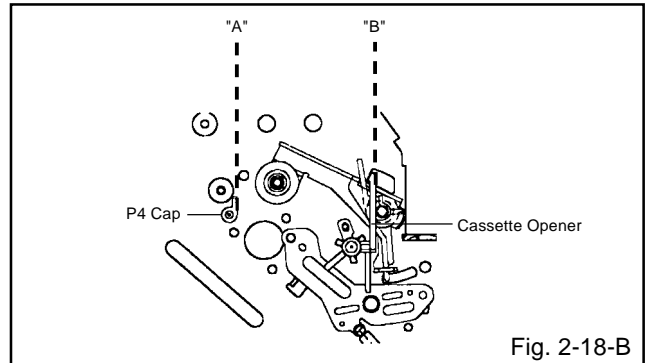

Fig. 2-18-B

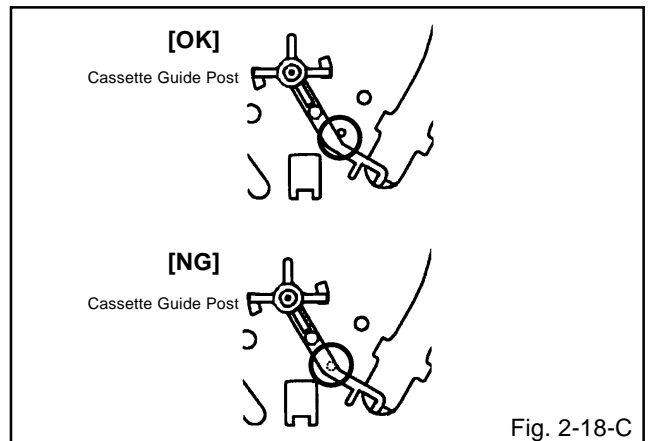

Fig. 2-18-C

DISASSEMBLY INSTRUCTIONS

3. REMOVAL OF DVD DECK PARTS

NOTE

1. Do not disassemble the DVD DECK PARTS except listed parts here. Minute adjustments are needed if the disassemble is done. If the repair is needed except listed parts, replace the DVD MECHA ASS'Y.

3-1: TRAY (Refer to Fig. 3-1-A)

1. Set the Tray opened. (Refer to the DISC REMOVAL METHOD AT NO POWER SUPPLY)
2. Unlock the 2 supports ① and remove the Tray.

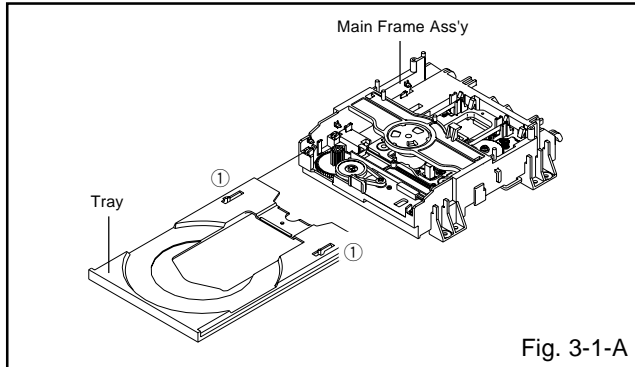

Fig. 3-1-A

NOTE

1. In case of the Tray installation, install them as the circled section of Fig. 3-1-B so that the each markers are met.

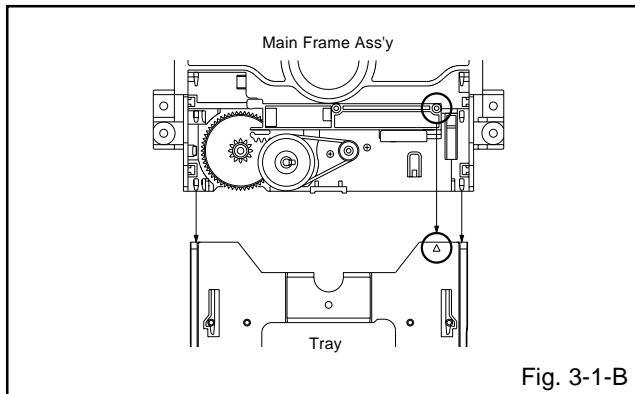

Fig. 3-1-B

3-2: MAIN CHASSIS ASS'Y (Refer to Fig. 3-2-A)

1. Remove the screw ①.
2. Unlock the 2 supports ②.
3. Remove the Insulator (R) from the Main Frame Ass'y.
4. Remove the Main Chassis Ass'y.

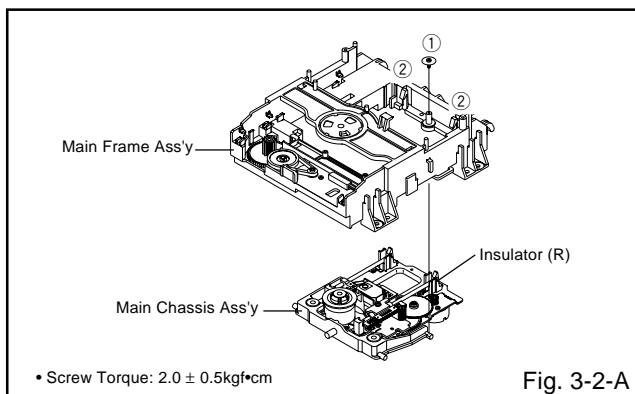

Fig. 3-2-A

NOTE

1. In case of the Main Chassis Ass'y, install it from (1) to (4) in order. (Refer to Fig. 3-2-B)
2. In case of the Main Chassis Ass'y installation, hook the wire on the Main Frame Ass'y as shown Fig. 3-2-C.

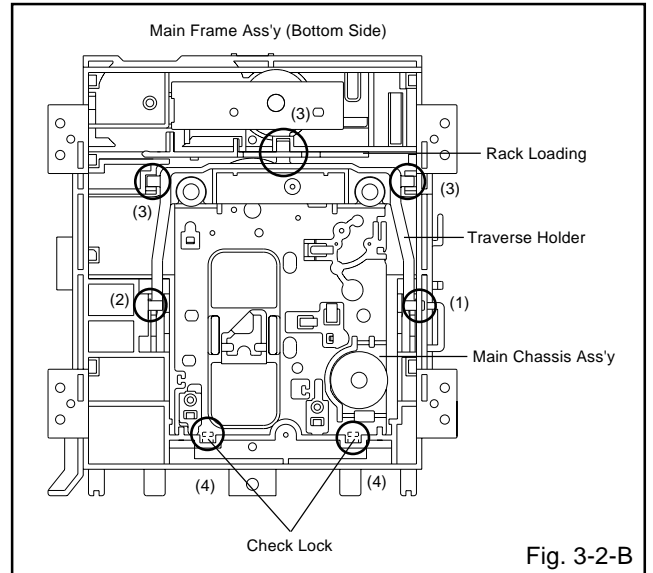

Fig. 3-2-B

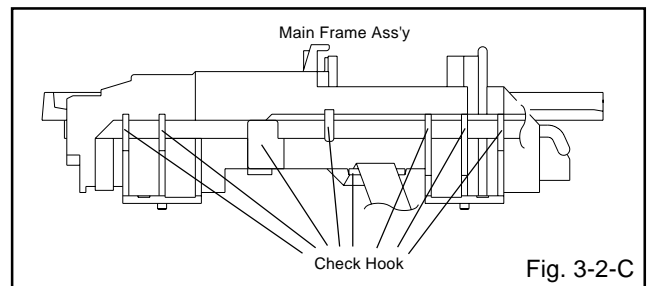

Fig. 3-2-C

3-3: LOADING MOTOR PCB ASS'Y/ LOADING BELT (Refer to Fig. 3-3-A)

1. Remove the Loading Belt.
2. Remove the screw ①.
3. Remove the 2 screws ②.
4. Remove the Loading Motor PCB Ass'y.
5. Remove the Pulley Gear.

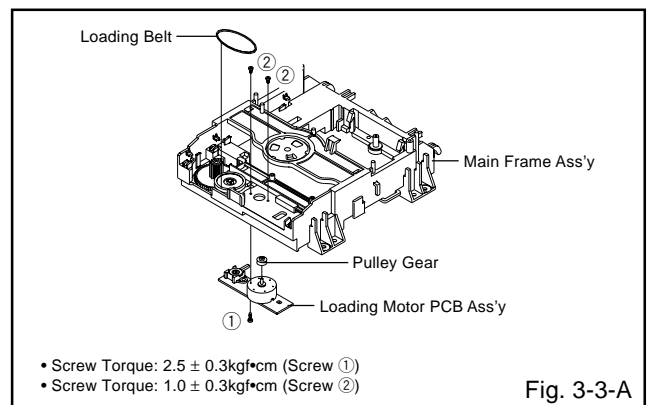
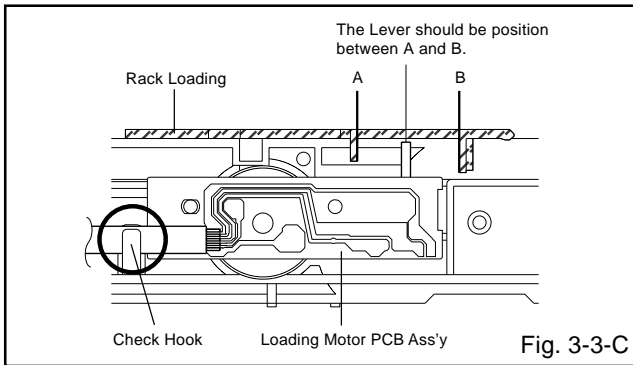
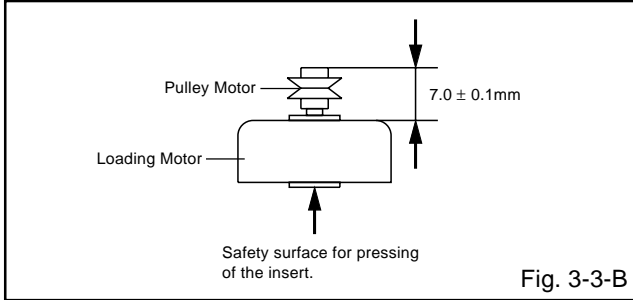

Fig. 3-3-A

DISASSEMBLY INSTRUCTIONS

NOTE

1. In case of the Pulley Motor installation, check if the value of the Fig. 3-3-B is correct.
2. When installing the Loading Motor PCB Ass'y, install it correctly as Fig. 3-3-C.
3. In case of the Loading Motor PCB Ass'y installation, hook the wire on the Main Frame Ass'y as shown Fig. 3-3-C.



3-4: RACK LOADING/MAIN GEAR/PULLEY GEAR (Refer to Fig. 3-4-A)

1. Press down the catcher ① and slide the Rack Loading.
2. Unlock the support ② and remove the Pulley Gear.
3. Remove the Main Gear.

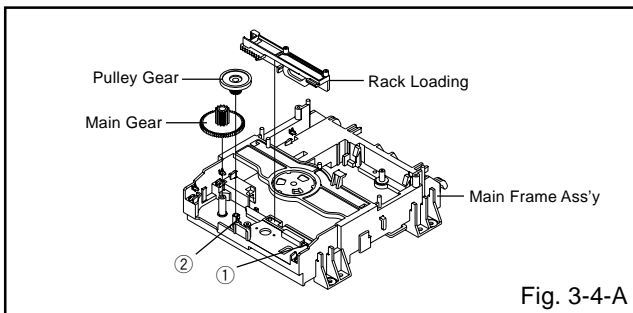

NOTE

1. In case of the Rack Loading installation, do not mesh it to the Main Gear as shown the Fig. 3-4-B.

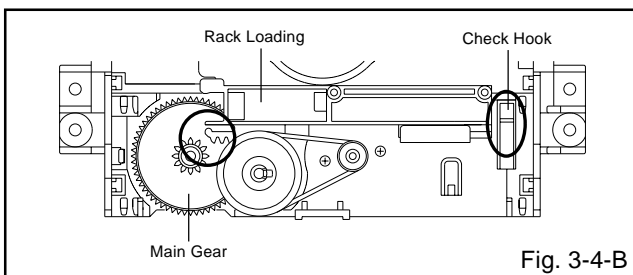

3-5: CLAMPER ASS'Y (Refer to Fig. 3-5-A)

1. Press the Clamper and rotate the Clamper Plate clockwise, then unlock the 3 supports ①.
2. Remove the Clamper Plate, Clamper Magnet and Clamper.

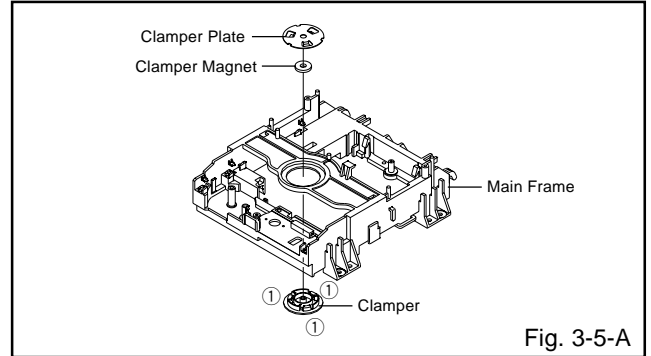

NOTE

1. In case of the Clamper Ass'y installation, install correctly as Fig. 3-5-B.

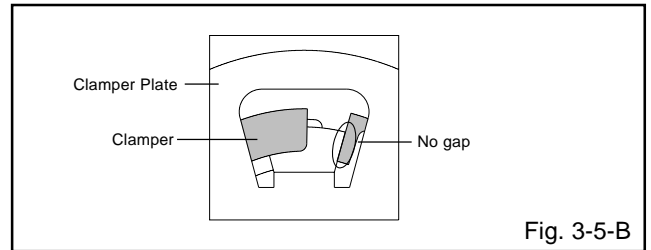

3-6: TRAVERSE HOLDER/INSULATOR (F)/INSULATOR (R) (Refer to Fig. 3-6-A)

1. Remove the Traverse Holder.
2. Remove the 2 Insulator (F).
3. Remove the Insulator (R).

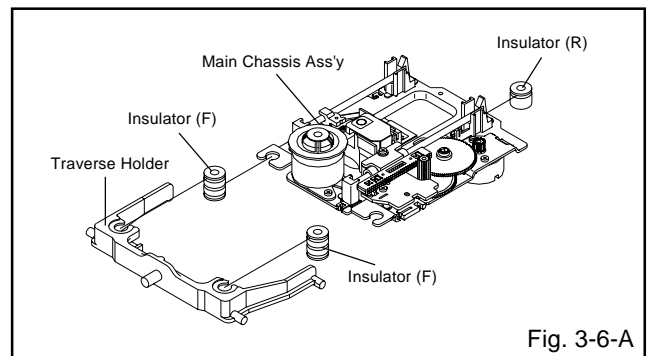

NOTE

1. In case of the Insulator (F) installation, install correctly as Fig. 3-6-B.
2. In case of the Insulator (R) installation, install correctly as Fig. 3-6-C.

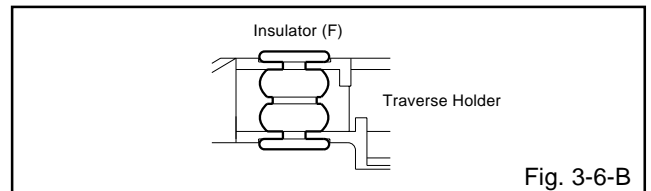

DISASSEMBLY INSTRUCTIONS

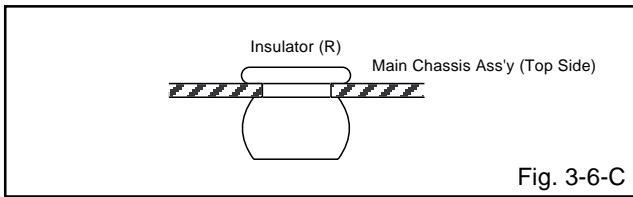

Fig. 3-6-C

3-7: RACK FEED ASS'Y/SWITCH PCB ASS'Y/FEED MOTOR (Refer to Fig. 3-7-A)

1. Remove the screw ①.
2. Remove the Rack Feed Ass'y.
3. Remove the screw ②.
4. Remove the Switch PCB Ass'y.
5. Remove the 2 screw ③.
6. Remove the Feed Motor.
7. Remove the Motor Gear.

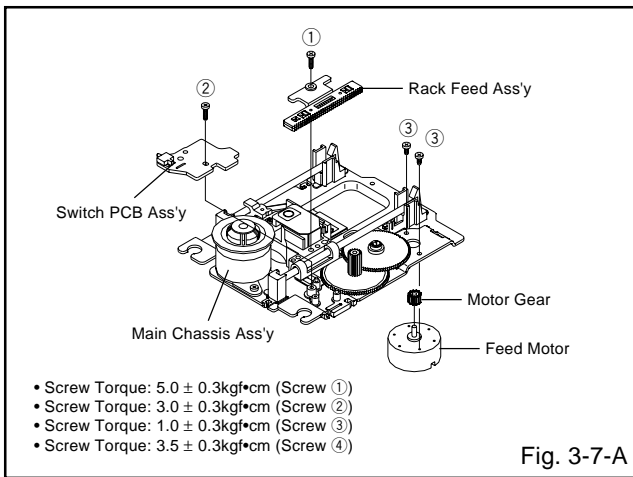

Fig. 3-7-A

NOTE

1. When pushing the Rack Feed in the direction of the arrow, it should be restored to the original position by the spring force. (Refer to Fig. 3-7-B)
2. In case of the Motor Gear installation, check if the value of the Fig. 3-7-C is correct.
3. When installing the wire of the Switch PCB Ass'y, install it correctly as Fig. 3-7-D.
4. After the assembly of the Main Chassis Ass'y, hook the wire on the Main Chassis Ass'y as shown Fig. 3-7-E.

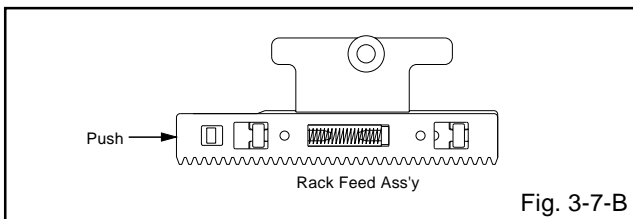

Fig. 3-7-B

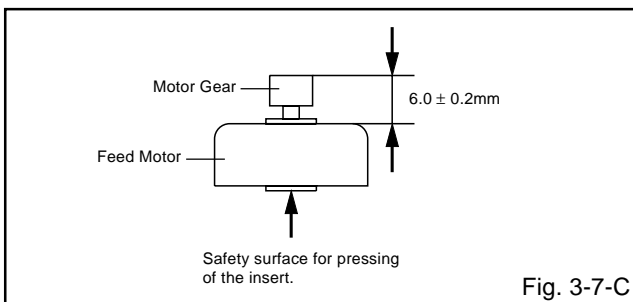

Fig. 3-7-C

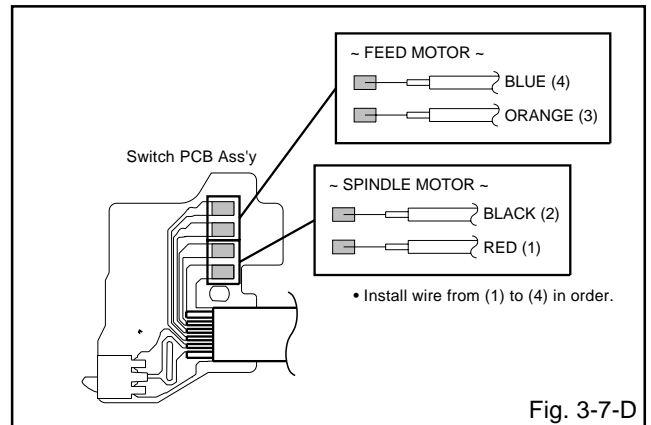

Fig. 3-7-D

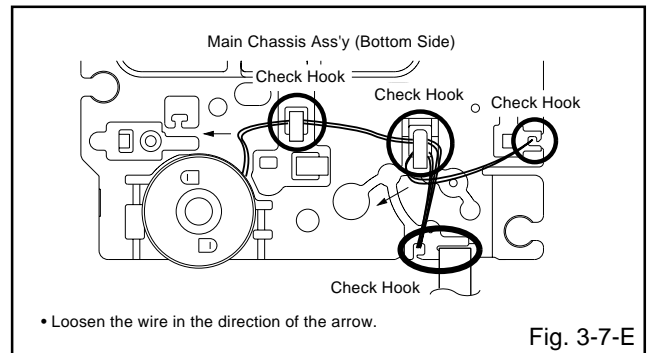

Fig. 3-7-E

DISASSEMBLY INSTRUCTIONS

4. REMOVAL AND INSTALLATION OF FLAT PACKAGE IC

REMOVAL

1. Put the Masking Tape (cotton tape) around the Flat Package IC to protect other parts from any damage. (Refer to Fig. 4-1.)

NOTE

Masking is carried out on all the parts located within 10 mm distance from IC leads.

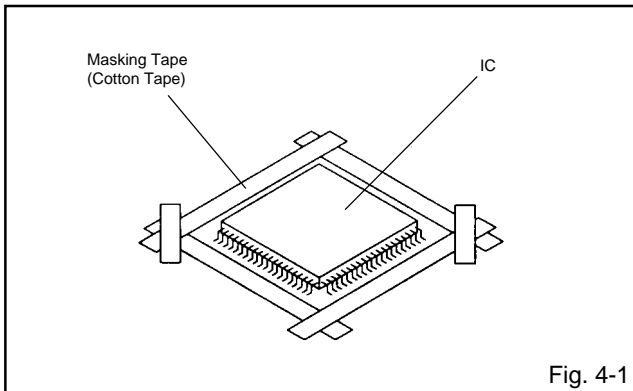

2. Heat the IC leads using a blower type IC desoldering machine. (Refer to Fig. 4-2.)

NOTE

Do not add the rotating and the back and forth directions force on the IC, until IC can move back and forth easily after desoldering the IC leads completely.

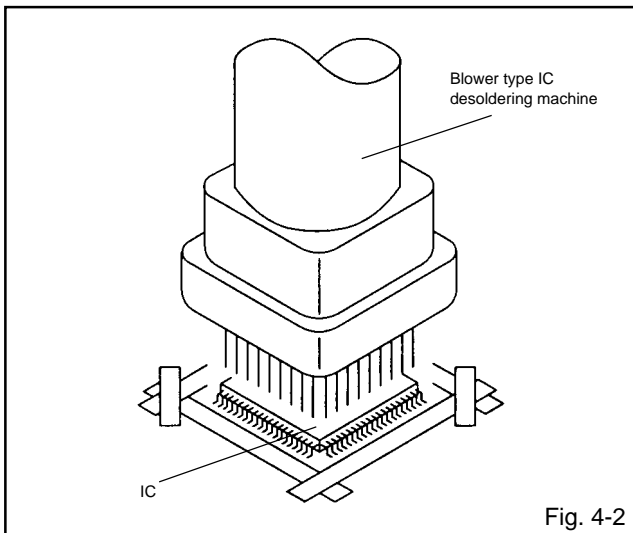

3. When IC starts moving back and forth easily after desoldering completely, pickup the corner of the IC using a tweezers and remove the IC by moving with the IC desoldering machine. (Refer to Fig. 4-3.)

NOTE

Some ICs on the PCB are affixed with glue, so be careful not to break or damage the foil of each IC leads or solder lands under the IC when removing it.

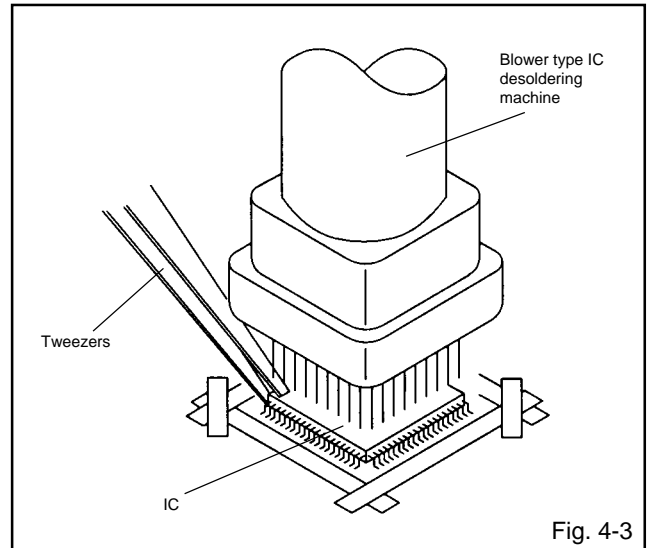

4. Peel off the Masking Tape.
5. Absorb the solder left on the pattern using the Braided Shield Wire. (Refer to Fig. 4-4.)

NOTE

Do not move the Braided Shield Wire in the vertical direction towards the IC pattern.

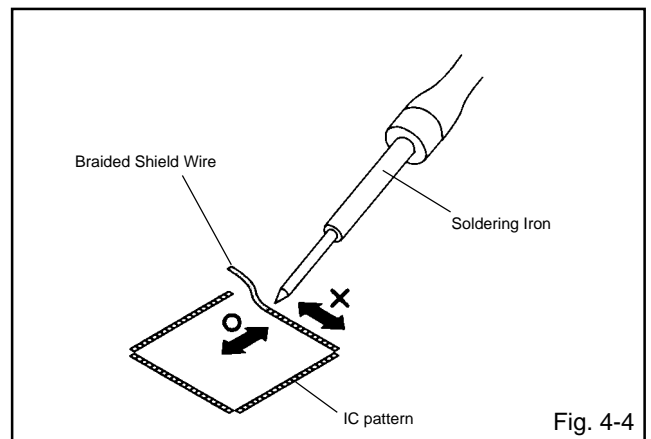

DISASSEMBLY INSTRUCTIONS

INSTALLATION

1. Take care of the polarity of new IC and then install the new IC fitting on the printed circuit pattern. Then solder each lead on the diagonal positions of IC temporarily. (Refer to Fig. 4-5.)

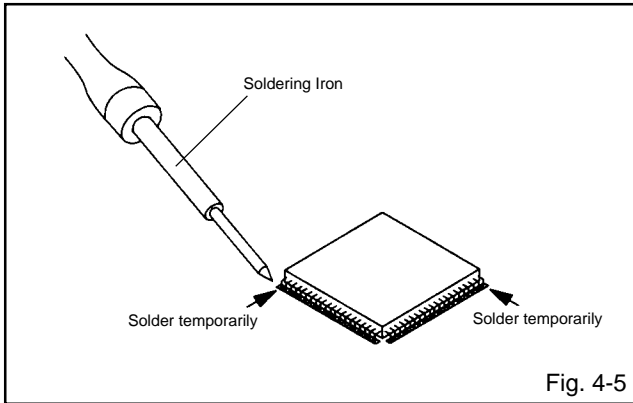

2. Supply the solder from the upper position of IC leads sliding to the lower position of the IC leads. (Refer to Fig. 4-6.)

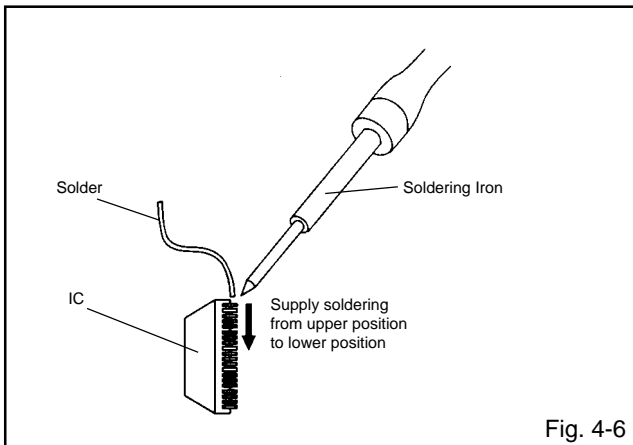

3. Absorb the solder left on the lead using the Braided Shield Wire. (Refer to Fig. 4-7.)

NOTE

Do not absorb the solder to excess.

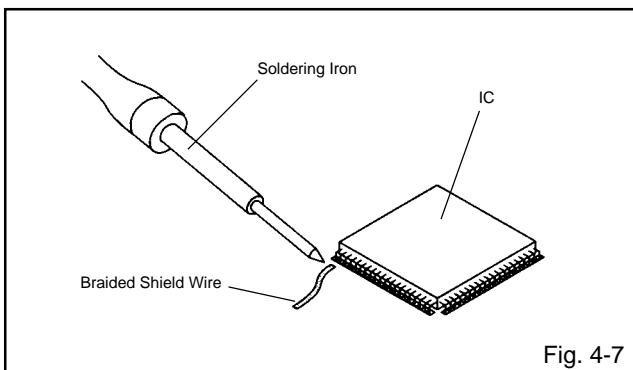

4. When bridge-soldering between terminals and/or the soldering amount are not enough, resolder using a Thin-tip Soldering Iron. (Refer to Fig. 4-8.)

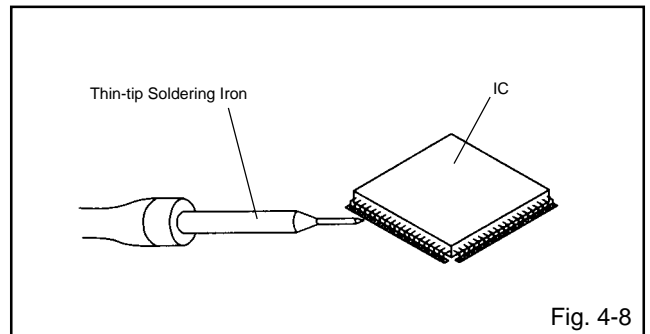

5. Finally, confirm the soldering status on four sides of the IC using a magnifying glass. Confirm that no abnormality is found on the soldering position and installation position of the parts around the IC. If some abnormality is found, correct by resoldering.

NOTE

When the IC leads are bent during soldering and/or repairing, do not repair the bending of leads. If the bending of leads are repaired, the pattern may be damaged. So, be always sure to replace the IC in this case.

KEY TO ABBREVIATIONS

A	A/C	: Audio/Control	H.SW	: Head Switch	
	ACC	: Automatic Color Control	Hz	: Hertz	
	AE	: Audio Erase	I	IC	: Integrated Circuit
	AFC	: Automatic Frequency Control		IF	: Intermediate Frequency
	AFT	: Automatic Fine Tuning		IND	: Indicator
	AFT DET	: Automatic Fine Tuning Detect		INV	: Inverter
	AGC	: Automatic Gain Control	K	KIL	: Killer
	AMP	: Amplifier	L	L	: Left
	ANT	: Antenna		LED	: Light Emitting Diode
	A.PB	: Audio Playback		LIMIT AMP	: Limiter Amplifier
	APC	: Automatic Phase Control		LM, LDM	: Loading Motor
	ASS'Y	: Assembly		LP	: Long Play
	AT	: All Time		L.P.F	: Low Pass Filter
	AUTO	: Automatic		LUMI.	: Luminance
	A/V	: Audio/Video	M	M	: Motor
B	BGP	: Burst Gate Pulse		MAX	: Maximum
	BOT	: Beginning of Tape		MINI	: Minimum
	BPF	: Bandpass Filter		MIX	: Mixer, mixing
	BRAKE SOL	: Brake Solenoid		MM	: Monostable Multivibrator
	BUFF	: Buffer		MOD	: Modulator, Modulation
	B/W	: Black and White		MPX	: Multiplexer, Multiplex
C	C	: Capacitance, Collector		MS SW	: Mecha State Switch
	CASE	: Cassette	N	NC	: Non Connection
	CAP	: Capstan		NR	: Noise Reduction
	CARR	: Carrier	O	OSC	: Oscillator
	CH	: Channel		OPE	: Operation
	CLK	: Clock	P	PB	: Playback
	CLOCK (SY-SE)	: Clock (Syscon to Servo)		PB CTL	: Playback Control
	COMB	: Combination, Comb Filter		PB-C	: Playback-Chrominance
	CONV	: Converter		PB-Y	: Playback-Luminance
	CPM	: Capstan Motor		PCB	: Printed Circuit Board
	CTL	: Control		P. CON	: Power Control
	CYL	: Cylinder		PD	: Phase Detector
	CYL-M	: Cylinder-Motor		PG	: Pulse Generator
	CYL SENS	: Cylinder-Sensor		P-P	: Peak-to Peak
D	DATA (SY-CE)	: Data (Syscon to Servo)	R	R	: Right
	dB	: Decibel		REC	: Recording
	DC	: Direct Current		REC-C	: Recording-Chrominance
	DD Unit	: Direct Drive Motor Unit		REC-Y	: Recording-Luminance
	DEMODO	: Demodulator		REEL BRK	: Reel Brake
	DET	: Detector		REEL S	: Reel Sensor
	DEV	: Deviation		REF	: Reference
E	E	: Emitter		REG	: Regulated, Regulator
	EF	: Emitter Follower		REW	: Rewind
	EMPH	: Emphasis		REV, RVS	: Reverse
	ENC	: Encoder		RF	: Radio Frequency
	ENV	: Envelope		RMC	: Remote Control
	EOT	: End of Tape		RY	: Relay
	EQ	: Equalizer	S	S. CLK	: Serial Clock
	EXT	: External		S. COM	: Sensor Common
F	F	: Fuse		S. DATA	: Serial Data
	FBC	: Feed Back Clamp		SEG	: Segment
	FE	: Full Erase		SEL	: Select, Selector
	FF	: Fast Forward, Flipflop		SENS	: Sensor
	FG	: Frequency Generator		SER	: Search Mode
	FL SW	: Front Loading Switch		SI	: Serial Input
	FM	: Frequency Modulation		SIF	: Sound Intermediate Frequency
	FSC	: Frequency Sub Carrier		SO	: Serial Output
	FWD	: Forward		SOL	: Solenoid
G	GEN	: Generator		SP	: Standard Play
	GND	: Ground		STB	: Serial Strobe
H	H.P.F	: High Pass Filter		SW	: Switch

KEY TO ABBREVIATIONS

S	SYNC	:	Synchronization
	SYNC SEP	:	Sync Separator, Separation
T	TR	:	Transistor
	TRAC	:	Tracking
	TRICK PB	:	Trick Playback
	TP	:	Test Point
U	UNREG	:	Unregulated
V	V	:	Volt
	VCO	:	Voltage Controlled Oscillator
	VIF	:	Video Intermediate Frequency
	VP	:	Vertical Pulse, Voltage Display
	V.PB	:	Video Playback
	VR	:	Variable Resistor
	V.REC	:	Video Recording
	VSF	:	Visual Search Fast Forward
	VSR	:	Visual Search Rewind
	VSS	:	Voltage Super Source
	V-SYNC	:	Vertical-Synchronization
	VT	:	Voltage Tuning
X	X'TAL	:	Crystal
Y	Y/C	:	Luminance/Chrominance

SERVICE MODE LIST

This unit provided with the following SERVICE MODES so you can repair, examine and adjust easily.

To enter to the SERVICE MODE function, press and hold both buttons simultaneously on the main unit or on the main unit and on the remote control for more than a standard time in the appropriate condition. (See below chart.)

In case of the main unit and remote control, press the remote control buttons first, then press the main unit buttons.

Set Condition	Set Key	Set Key	Standard Time	Operations
VCR mode	CH UP	FF	2 sec.	PLAY/REC total hours are displayed on the TV Monitor. Refer to the "PREVENTIVE CHECKS AND SERVICE INTERVALS" (CONFIRMATION OF HOURS USED). Can be checked of the INITIAL DATA of MEMORY IC. Refer to the "WHEN REPLACING EEPROM (MEMORY) IC".
VCR mode	CH UP	PLAY	2 sec.	Initialization of the factory on VCR. NOTE: Do not use this for the normal servicing. If you set a factory initialization, the memories are reset such as the clock setting, the channel setting, and PLAY/REC total hours.
VCR mode (Playback)	CH UP	STOP	2 sec.	Adjust the PG SHIFTER automatically. Refer to the "ELECTRICAL ADJUSTMENT".
Power Off	CH DOWN	POWER	2 sec.	VCR operation mode at no connection of DVD. Refer to the "PREPARATION FOR SERVICING" NOTE: Although the DVD is connected, the DVD mode cannot be selected.

Set Condition	Set Key	Remocon Key	Standard Time	Operations
DVD mode (No disc)	REC/OTR	4	2 sec.	Initialization of the factory on DVD. NOTE: Do not use this for the normal servicing. This function will only work without the setting of DVD disc at DVD mode. While pressing the Remocon Key for more than 2 seconds, press the Set Key simultaneously.
DVD mode (No disc)	STOP	7	3 sec.	Releasing of PARENTAL LOCK. Refer to the "PARENTAL CONTROL - RATING LEVEL". NOTE: The function will only work without the setting of DVD disc at DVD mode.

Method	Operations
Press the ATR button on the remote control for more than 2 seconds during PLAY.	Adjusting of the Tracking to the center position. Refer to the "MECHANICAL ADJUSTMENT" (GUIDE ROLLER) and "ELECTRICAL ADJUSTMENT" (PG SHIFTER).
Make the short circuit between the test point of SERVICE and the GND.	The BOT, EOT, and the Reel Sensor do not work and the VCR deck can be operated without a cassette tape. Refer to the "PREPARATION FOR SERVICING"

PREVENTIVE CHECKS AND SERVICE INTERVALS

The following standard table depends on environmental conditions and usage.

Parts replacing time does not mean the life span for individual parts.

Also, long term storage or misuse may cause transformation and aging of rubber parts.

The following list means standard hours, so the checking hours depends on the conditions.

Time Parts Name	500 hours	1,000 hours	1,500 hours	2,000 hours	2,500 hours	Notes
Audio Control Head	■	■	■	●	●	Clean those parts in contact with the tape.
Full Erase Head (Recorder only)	■	■	■	●	●	
Capstan Belt		●	●	●	●	Clean the rubber, and parts which the rubber touches.
Pinch Roller	■	●	●	●	●	
Capstan DD Unit		●	●	●	●	
Loading Motor					●	
Tension Band		●	●	●	●	
T Brake Band		●	●	●	●	
Clutch Ass'y		●	●	●	●	
Idler Arm Ass'y		●	●	●	●	
Capstan Shaft	■	■	■	■	■	
Tape Running Guide Post	■	■	■	■	■	
Cylinder Unit	■	●	●	●	●	Clean the Head

■ : Clean

● : Check it and if necessary, replace it.

CONFIRMATION OF HOURS USED

PLAY/REC total hours can be checked on the screen.

Total hours are displayed in 16 system of notation.

NOTE: If you set a factory initialization, the total hours is reset to "0".

1. Connect the set to TV Monitor.
2. Turn on the POWER, and set to the VCR mode.
3. Press both CH UP button on the set and the FF button on the set for more than 2 seconds.
The **Fig. 1** screen will appear on TV Monitor.
4. After the confirmation of using hours, turn off the power.

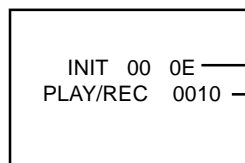

Fig. 1

Initial setting content of MEMORY IC.

PLAY/REC total hours.

= (16 x 16 x 16 x thousands digit value)

+ (16 x 16 x hundreds digit value)

+ (16 x tens digit value)

+ (ones digit value)

PREVENTIVE CHECKS AND SERVICE INTERVALS

CLEANING

NOTE

After cleaning the heads with isopropyl alcohol, do not run a tape until the heads dry completely. If the heads are not completely dry and alcohol gets on the tape, damage may occur.

1. AUDIO CONTROL HEAD

Clean the Audio Control Head with the cotton stick soaked by alcohol. Clean the full erase head in the same manner. **(Refer to the figure below.)**

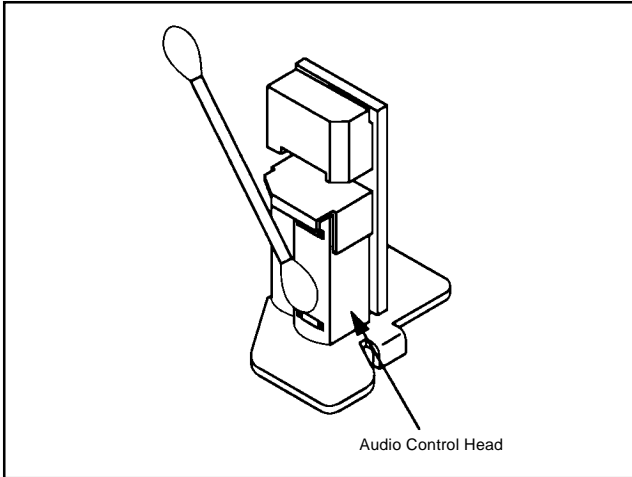

2. TAPE RUNNING SYSTEM

When cleaning the tape transport system, use the gauze moistened with isopropyl alcohol.

3. CYLINDER

Wrap a piece of chamois around your finger. Dip it in isopropyl alcohol. Hold it to the cylinder head softly. Turn the cylinder head counterclockwise to clean it (in the direction of the arrow). **(Refer to the figure below.)**

NOTE

Do not exert force against the cylinder head. Do not move the chamois upward or downward on the head. Use the chamois one by one.

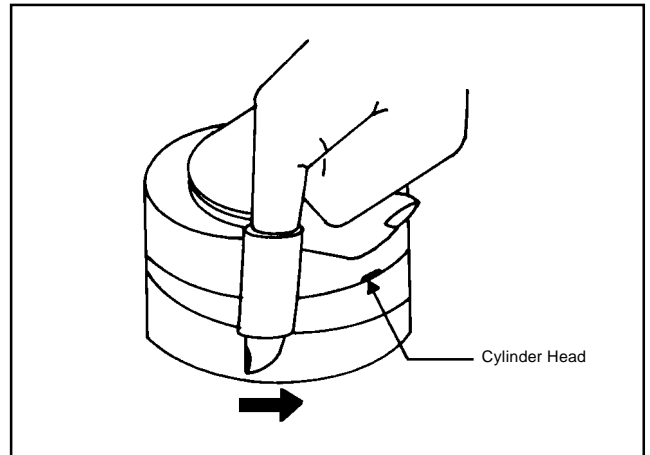

WHEN REPLACING EEPROM (MEMORY) IC

If a service repair is undertaken where it has been required to change the MEMORY IC, the following steps should be taken to ensure correct data settings while making reference to TABLE 1.

NOTE: INI 34 and INI 35 cannot be set. Because, the total time for the PLAY/REC of the main unit is recorded.

INIT	+0	+1	+2	+3	+4	+5	+6	+7	+8	+9	+A	+B	+C	+D	+E	+F
00	0E	D0	DC	60	C4	64	4A	86	0B	28	86	32	0A	08	0A	02
10	AF	97	95	8A	A0	57	31	04	88	A5	9F	3A	00	10	BF	00
20	3A	11	22	70	61	3A	3A	00	0B	00	40	85	9A	B0	00	37
30	03	17	---	---	---	---	---	---	---	---	---	---	---	---	---	---

Table 1

1. Connect the set to TV Monitor.
2. Turn on the POWER, and set to the VCR mode.
3. Press both CH UP button on the set and the FF button on the set for more than 2 seconds.
ADDRESS and DATA will appear on TV Monitor as **Fig 1** .



Fig. 1

4. ADDRESS is now selected and should "blink". Using the Tracking + or - button on the remote, step through the ADDRESS until required ADDRESS to be changed is reached.
5. Press ENTER to select DATA. When DATA is selected, it will "blink".
6. Again, step through the DATA using Tracking + or - button until required DATA value has been selected.
7. Pressing ENTER will take you back to ADDRESS for further selection if necessary.
8. Repeat steps 4 to 7 until all data has been checked.
9. When satisfied correct DATA has been entered, turn POWER off (return to STANDBY MODE) to finish DATA input.

After the data input, set to the initializing of shipping.

10. Turn on the POWER, and set to the VCR mode.
 11. Press both CH UP button on the set and the PLAY button on the set for more than 2 seconds.
 12. After the finishing of the initializing of shipping, the unit will turn off automatically.
- The unit will now have the correct DATA for the new MEMORY IC.

SERVICING FIXTURES AND TOOLS

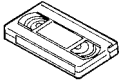
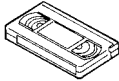
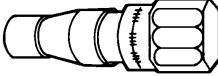
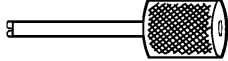
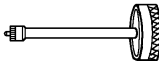
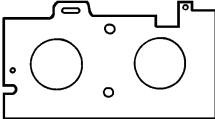
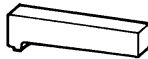
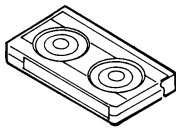
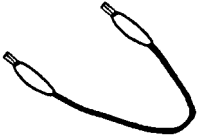
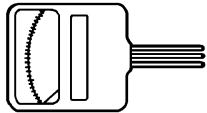
<p>(For 2 heads model) VHS Alignment Tape JG001 (VN₂S-LI6³) JG001A (VN₂S-CO¹³) JG001Q (VN₂S-LI6³H) JG001T (VN₂S-X6³)</p> 	<p>(For 4 heads model) VHS Alignment Tape JG001B (VN₁S-LI6³) JG001I (VN₁S-CO¹³) JG001P (VN₁S-LI6³H) JG001S (VN₁S-X6³)</p> 	<p>JG002B Adapter JG002E Dial Torque Gauge (10~90gf•cm) JG002F (60~600gf•cm)</p> 	<p>JG005 Post Adjustment Screwdriver Part No. SV-TG0-030-000 (small)</p> 
<p>JG153 X Value Adjustment Screwdriver</p> 	<p>JG022 Master Plane</p> 	<p>JG024A Reel Disk Height Adjustment Jig</p> 	<p>JG100A Torque Tape (VHT-063)</p> 
<p>JG154 Cable</p> 	<p>JG185 Tentelometer</p> 		

Ref. No.	Part No.	Parts Name	Remarks
JG001	APJG001000	VHS Alignment Tape	Monoscope, 6KHz (For 2 heads model)
JG001A	APJG001A00	VHS Alignment Tape	Color Bar, 1KHz (For 2 heads model)
JG001Q	APJG001Q00	VHS Alignment Tape	Hi-Fi Audio (For 2 heads model)
JG001T	APJG001T00	VHS Alignment Tape	X Value Adjustment (For 2 heads model)
JG001B	APJG001B00	VHS Alignment Tape	Monoscope, 6KHz (For 4 heads model)
JG001I	APJG001I00	VHS Alignment Tape	Color Bar, 1KHz (For 4 heads model)
JG001P	APJG001P00	VHS Alignment Tape	Hi-Fi Audio (For 4 heads model)
JG001S	APJG001S00	VHS Alignment Tape	X Value Adjustment (For 4 heads model)
JG002B	APJG002B00	Adapter	VSR Torque, Brake Torque (S Reel/T Reel Ass'y)
JG002E	APJG002E00	Dial Torque Gauge (10~90gf•cm)	Brake Torque (T Reel Ass'y)
JG002F	APJG002F00	Dial Torque Gauge (60~600gf•cm)	VSR Torque, Brake Torque (S Reel)
JG005	APJG005000	Post Adjustment Screwdriver	Guide Roller Adjustment
JG153	APJG153000	X Value Adjustment Screwdriver	X Value Adjustment
JG022	APJG022000	Master Plane	Reel Disk Height Adjustment
JG024A	APJG024A00	Reel Disk Height Adjustment Jig	Reel Disk Height Adjustment
JG100A	APJG100A00	Torque Tape (VHT-063)	Playback Torque, Back Tension Torque During Playback
JG154	APJG154000	Cable	Used to connect the test point of SERVICE and GROUND
JG185	APJG185000	Tentelometer	Confirmation of Tape Tension on Playback

PREPARATION FOR SERVICING

- While pressing the CH DOWN button on the set for more than 2 seconds, press the POWER button on the set simultaneously at the Power OFF. Although the DVD is connected, the DVD mode cannot be selected.
- Short circuit between **TP3001** and **Ground** with the cable JG154.
(The BOT, EOT, and the Reel Sensor do not work and the VCR deck can be operated without a cassette tape.)
- In case of using a cassette tape, press the STOP/EJECT button to insert or eject a cassette tape.
Turn on the power and re-check the cable before checking the trouble points.

When you servicing with connection of DVD, perform the operations above step 2 to step 3.

MECHANICAL ADJUSTMENTS

1. CONFIRMATION AND ADJUSTMENT

Read the following NOTES before starting work.

- Place an object which weighs between 450g~500g on the Cassette Tape to keep it steady when you want to make the tape run without the Cassette Holder. (Do not place an object which weighs over 500g.)

1-1: CONFIRMATION AND ADJUSTMENT OF REEL DISK HEIGHT

- Turn on the power and set to the STOP mode.
- Set the master plane (**JG022**) and reel disk height adjustment jig (**JG024A**) on the mechanism framework, taking care not to scratch the drum, as shown in **Fig. 1-1-A**.
- While turning the reel and confirm the following points. Check if the surface "A" of reel disk is lower than the surface "B" of reel disk height adjustment jig (**JG024A**) and is higher than the surface "C". If it is not passed, place the height adjustment washers and adjust to 10(+2, -0)mm.
- Adjust the other reel in the same way.

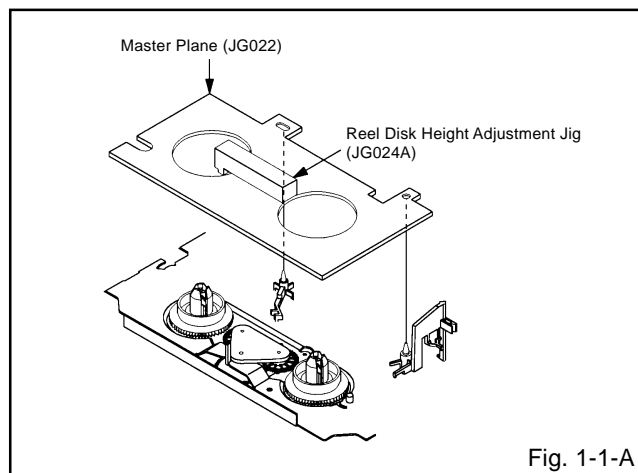

Fig. 1-1-A

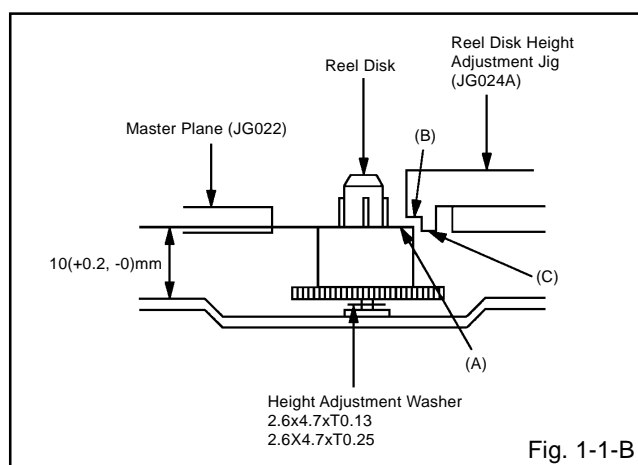

Fig. 1-1-B

1-2: CONFIRMATION AND ADJUSTMENT OF TENSION POST POSITION

- Set to the PLAY mode.
- Adjust the adjusting section for the Tension Arm position so that the Tension Arm top is within the standard line of Main Chassis.
- While turning the S Reel clockwise, confirm that the edge of the Tension Arm is located in the position described above.

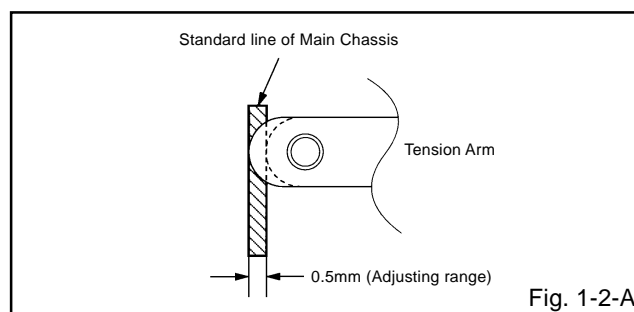

Fig. 1-2-A

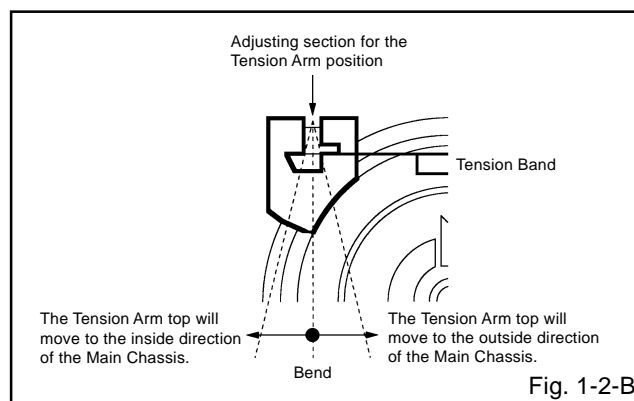

Fig. 1-2-B

1-3: CONFIRMATION OF PLAYBACK TORQUE AND BACK TENSION TORQUE DURING PLAYBACK

- Load a video tape (T-120) recorded in standard speed mode. Set the unit to the PLAY mode.
- Install the tentelometer (**JG185**) as shown in **Fig. 1-3**. Confirm that the meter indicates $20 \pm 2\text{gf}$ in the beginning of playback.

• USING A CASSETTE TYPE TORQUE TAPE (**JG100A**)

- After confirmation and adjustment of Tension Post position (Refer to item 1-2), load the cassette type torque tape (**JG100A**) and set to the PLAY mode.
- Confirm that the right meter of the torque tape indicates 50~90gf•cm during playback in SP mode.
- Confirm that the left meter of the torque tape indicates 25~40gf•cm during playback in SP mode.

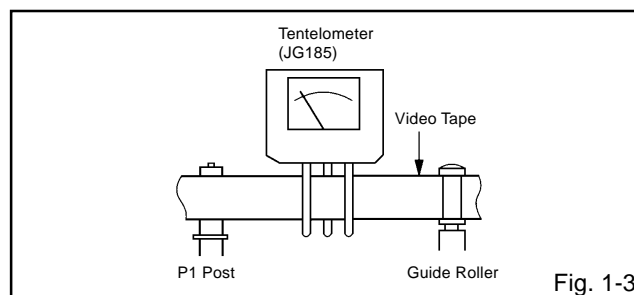

Fig. 1-3

MECHANICAL ADJUSTMENTS

1-4: CONFIRMATION OF VSR TORQUE

1. Install the Torque Gauge (**JG002F**) and Adapter (**JG002B**) on the S Reel. Set to the Picture Search (Rewind) mode. (Refer to Fig.1-4-B)
2. Then, confirm that it indicates 120~180gf•cm.

NOTE

Install the Torque Gauge on the reel disk firmly. Press the REW button to turn the reel disk.

1-5: CONFIRMATION OF REEL BRAKE TORQUE

(S Reel Brake) (Refer to Fig. 1-4-B)

1. Once set to the Fast Forward mode then set to the Stop mode. While, unplug the AC cord when the Pinch Roller Block is on the position of Fig. 1-4-A.
2. Move the Idler Ass'y from the S Reel.
3. Install the Torque Gauge (**JG002F**) and Adapter (**JG002B**) on the S Reel. Turn the Torque Gauge (**JG002F**) clockwise.
4. Then, confirm that it indicates 60~100gf•cm.

(T Reel Brake) (Refer to Fig. 1-4-B)

1. Once set to the Fast Forward mode then set to the Stop mode. While, unplug the AC cord when the Pinch Roller Block is on the position of Fig. 1-4-A.
2. Move the Idler Ass'y from the T Reel.
3. Install the Torque Gauge (**JG002E**) and Adapter (**JG002B**) on the T reel. Turn the Torque Gauge (**JG002E**) counterclockwise.
4. Then, confirm that it indicates 30~50gf•cm.

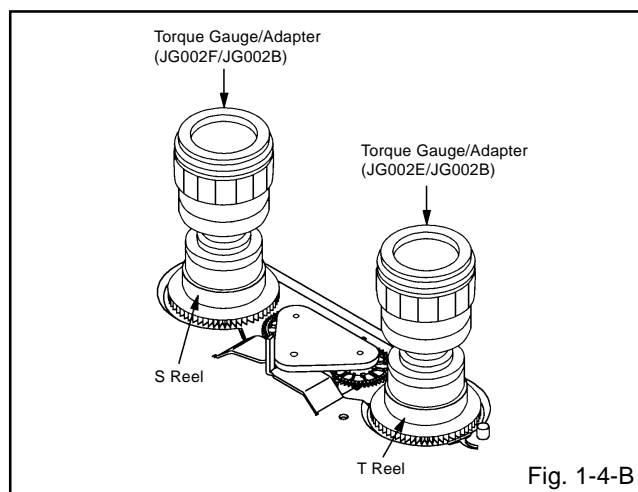
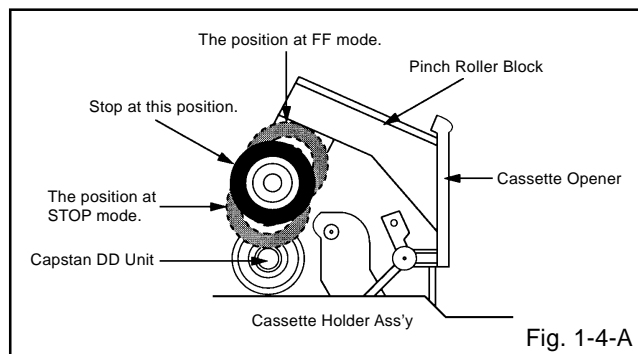

NOTE

If the torque is out of the range, replace the following parts.

Check item	Replacement Part
1-4	Idler Ass'y/Clutch Ass'y
1-5	S Reel side: S Reel/Tension Band/Tension Connect/Tension Arm Ass'y T Reel side: T Reel/T Brake Band//T Brake Spring/T Brake Arm

2. CONFIRMATION AND ADJUSTMENT OF TAPE RUNNING MECHANISM

Tape Running Mechanism is adjusted precisely at the factory. Adjustment is not necessary as usual. When you replace the parts of the tape running mechanism because of long term usage or failure, the confirmation and adjustment are necessary.

2-1: GUIDE ROLLER

1. Playback the VHS Alignment Tape (**JG001** or **JG001B**). (Refer to **SERVICING FIXTURE AND TOOLS**)
2. Connect CH-1 of the oscilloscope to **TP101 (Envelope)** and CH-2 to **TP3002 (SW Pulse)**.
3. Press and hold the ATR button on the remote control more than 2 seconds to set tracking to center.
4. Trigger with SW Pulse and observe the envelope. (Refer to Fig. 2-1-A)
5. When observing the envelope, adjust the Adjusting Driver (**JG005**) slightly until the envelope will be flat. Even if you press the Tracking Button, adjust so that flatness is not moved so much.
6. Adjust so that the A : B ratio is better than 3 : 2 as shown in Fig. 2-1-B, even if you press the Tracking Button to move the envelope (The envelope waveform will begin to decrease when you press the Tracking Button).
7. Adjust the PG shifter during playback. (Refer to the **ELECTRICAL ADJUSTMENTS**)

NOTE

After adjustment, confirm and adjust A/C head. (Refer to item 2-2)

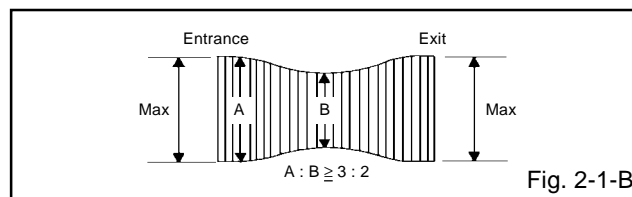
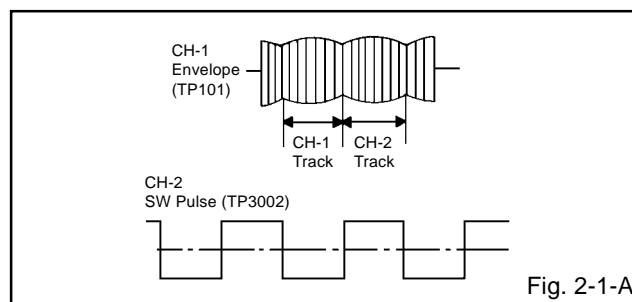

MECHANICAL ADJUSTMENTS

2-2: CONFIRMATION AND ADJUSTMENT OF AUDIO/CONTROL HEAD

When the Tape Running Mechanism does not work well, adjust the following items.

1. Playback the VHS Alignment Tape (**JG001** or **JG001B**).
(Refer to **SERVICING FIXTURE AND TOOLS**)
2. Confirm that the reflected picture of stamp mark is appeared on the tape prior to P4 Post as shown in **Fig. 2-2-A**.
 - a) When the reflected picture is distorted, turn the screw ① clockwise until the distortion is disappeared.
 - b) When the reflected picture is not distorted, turn the screw ① counterclockwise until little distortion is appeared, then adjust the a).
3. Turn the screw ② to set the audio level to maximum.
4. Confirm that the bottom of the Audio/Control Head and the bottom of the tape is shown in **Fig. 2-2-C**.
 - a) When the height is not correct, turn the screw ③ to adjust the height. Then, adjust the 1~3 again.

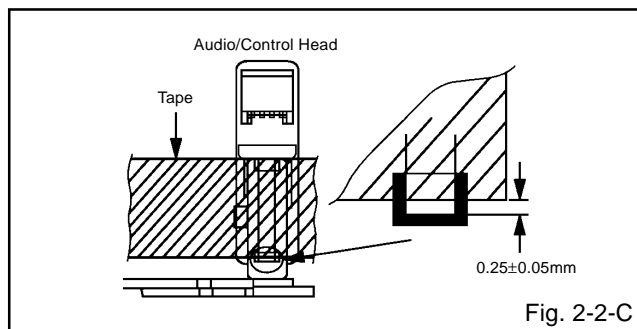
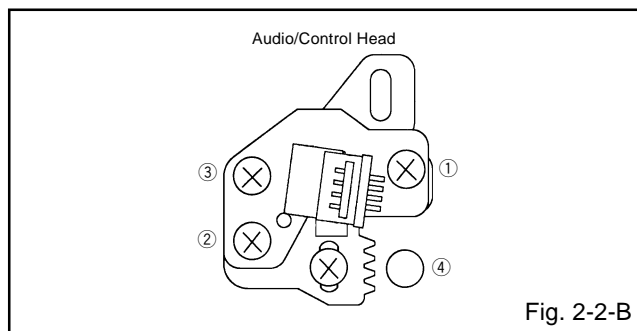
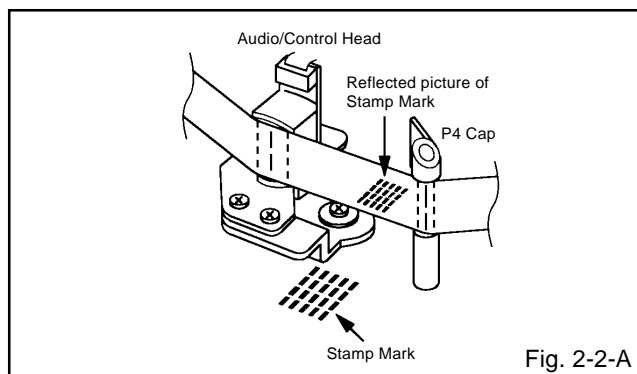

2-3: TAPE RUNNING ADJUSTMENT (X VALUE ADJUSTMENT)

1. Confirm and adjust the height of the Reel Disk.
(Refer to item 1-1)
2. Confirm and adjust the position of the Tension Post.
(Refer to item 1-2)
3. Adjust the Guide Roller. (Refer to item 2-1)
4. Confirm and adjust the Audio/Control Head.
(Refer to item 2-2)
5. Connect CH-1 of the oscilloscope to **TP3002**, CH-2 to **TP101** and CH-3 to **HOT side of Audio Out Jack**.
6. Playback the VHS Alignment Tape (**JG001S** or **JG001T**).
(Refer to **SERVICING FIXTURE AND TOOLS**)
7. Press and hold the ATR button on the remote control more than 2 seconds to set tracking to center.
8. Set the X Value adjustment driver (**JG153**) to the ④ of **Fig. 2-2-B**. Adjust X value so that the envelope waveform output becomes maximum. Check if the relation between Audio and Envelope waveform becomes (1) or (2) of **Fig. 2-3**.

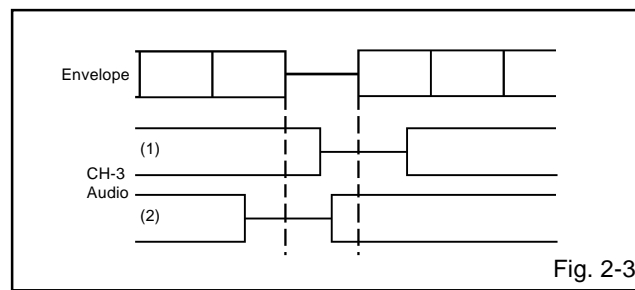

2-4: CONFIRM HI-FI AUDIO (Hi-Fi model only)

1. Connect CH-1 of the oscilloscope to **TP101** and CH-2 to the **Hi-Fi Audio Out Jack**.
2. Playback the VHS Alignment Tape (**JG001P** or **JG001Q**).
(Refer to **SERVICING FIXTURE AND TOOLS**)
3. Press and hold the ATR button on the remote control more than 2 seconds to set tracking to center.
4. Press the Tracking Up button and count number of steps which the audio output is changed from Hi-Fi (10KHz) to MONO (6KHz).
5. Press and hold the ATR button on the remote control more than 2 seconds to set tracking to center.
6. Press the Tracking Down button and count number of steps which the audio output is changed from Hi-Fi (10KHz) to MONO (6KHz).
7. If the difference are more than 3 steps, set the X Value adjustment driver (**JG153**) to ④ of **Fig. 2-2-B**. Change the X Value and adjust it so that the value becomes within 2 steps.

MECHANICAL ADJUSTMENTS

3. MECHANISM ADJUSTMENT PARTS LOCATION GUIDE

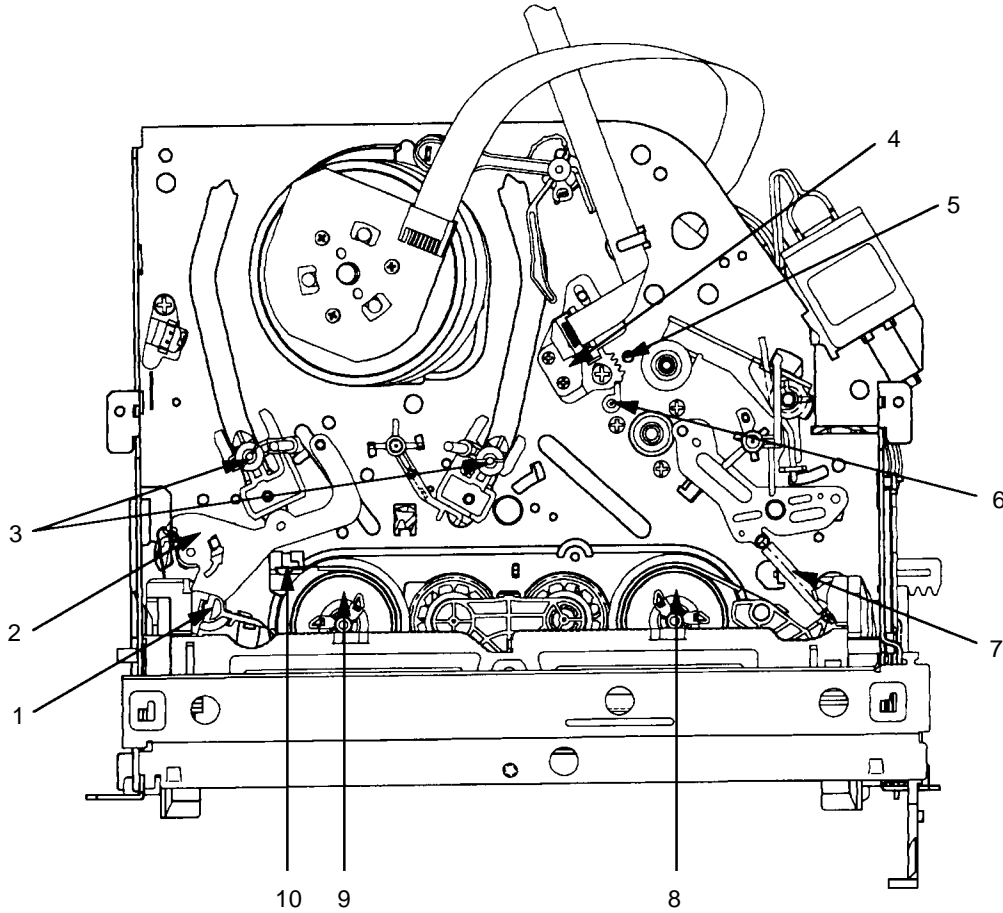

- | | |
|-----------------------------------|----------------------------------------------------|
| 1. Tension Connect | 6. P4 Post |
| 2. Tension Arm | 7. T Brake Spring |
| 3. Guide Roller | 8. T Reel |
| 4. Audio/Control Head | 9. S Reel |
| 5. X value adjustment driver hole | 10. Adjusting section for the Tension Arm position |

ELECTRICAL ADJUSTMENTS

Read and perform this adjustment when repairing the circuits or replacing electrical parts or PCB assemblies.

1. BASIC ADJUSTMENT

CAUTION

- When you exchange IC and Transistor for a heat sink, apply the silicon grease (**YG6260M**) on the contact section of the heat sink. Before applying new silicon grease, remove all the old silicon grease. (Old grease may cause damages to the IC and Transistor.)

1-1: PG SHIFTER

CONDITIONS

MODE-PLAYBACK

Input Signal-Alignment Tape (**JG001P**)

INSTRUCTIONS

1. Connect CH-1 on the oscilloscope to **TP3002** and CH-2 to **Video Out Jack**.
2. Playback the alignment tape. (**JG001P**)
3. Press and hold the Tracking-Auto button on the remote control more than 2 seconds to set tracking to center.
4. Press both CH UP button on the set and the STOP button on the set for more than 2 seconds.

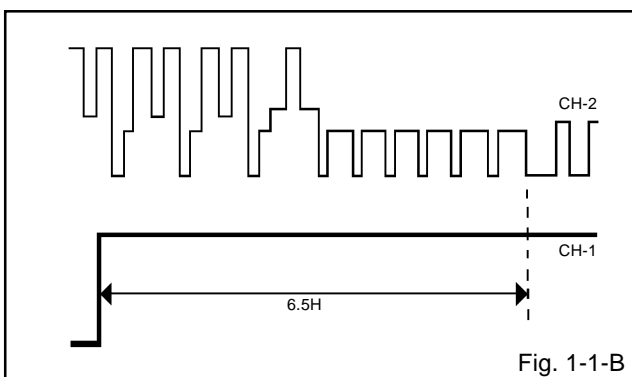
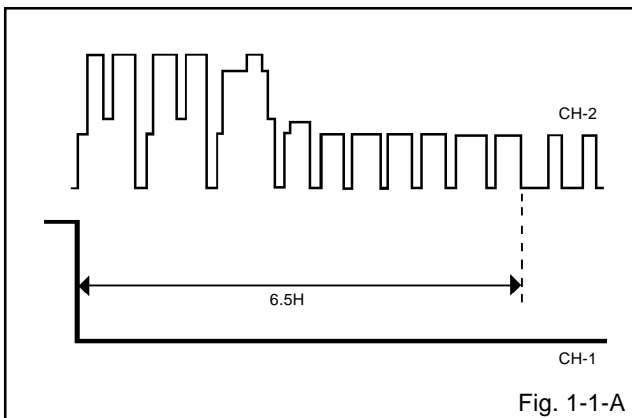

ELECTRICAL ADJUSTMENTS

2. ELECTRICAL ADJUSTMENT PARTS LOCATION GUIDE (WIRING CONNECTION)

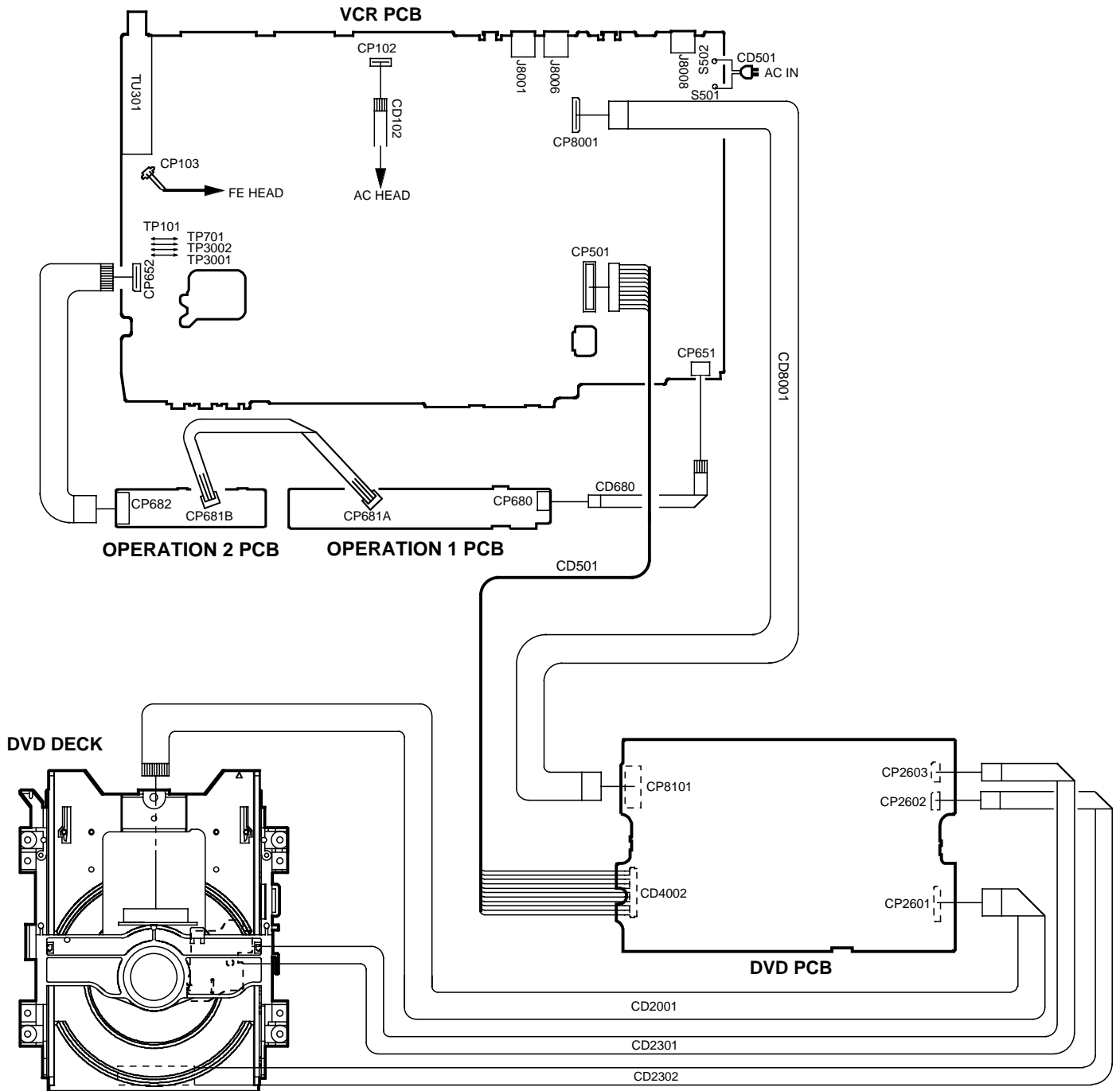

DVD BLOCK DIAGRAM

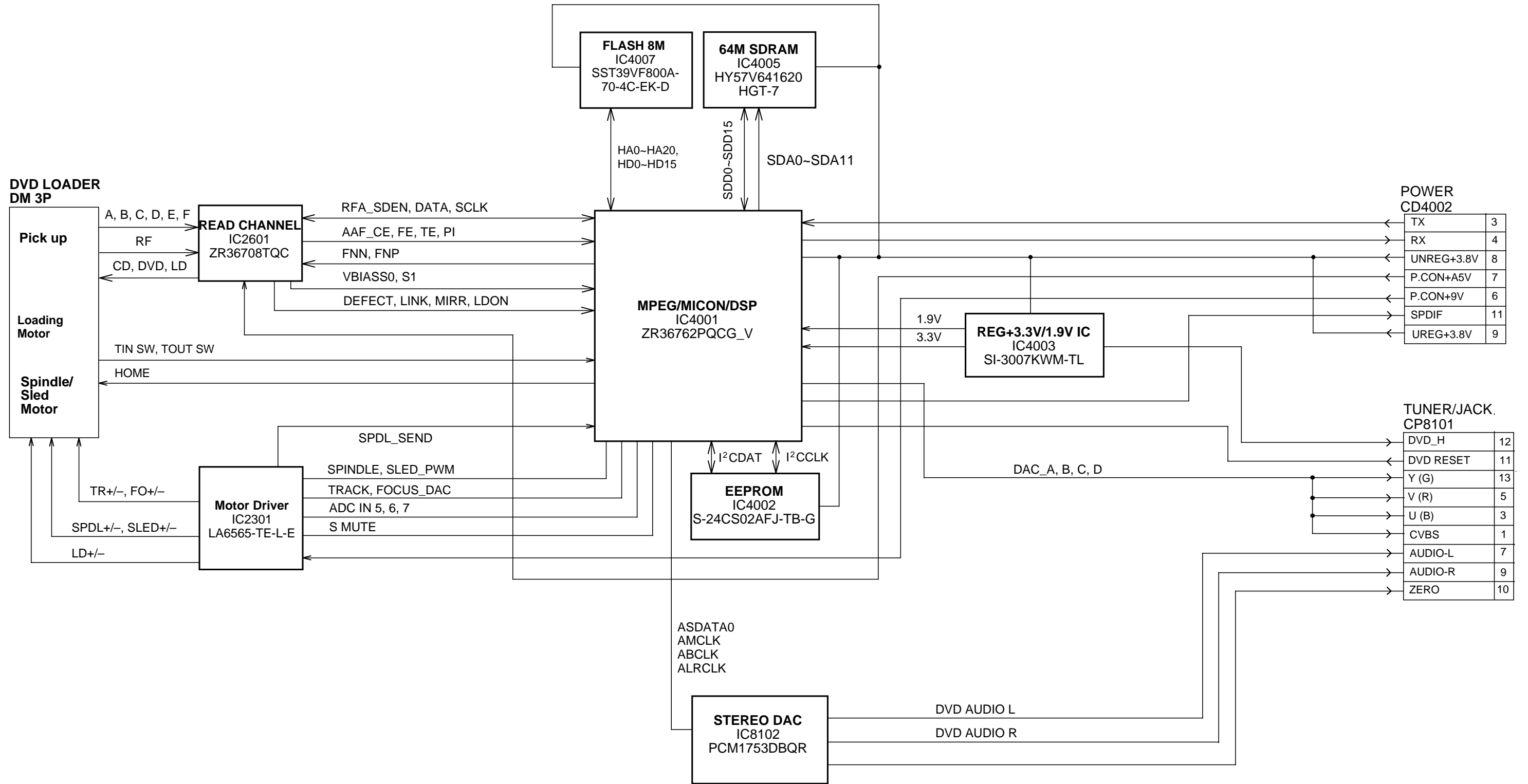

Y/C/AUDIO/CCD/HEAD MAP BLOCK DIAGRAM

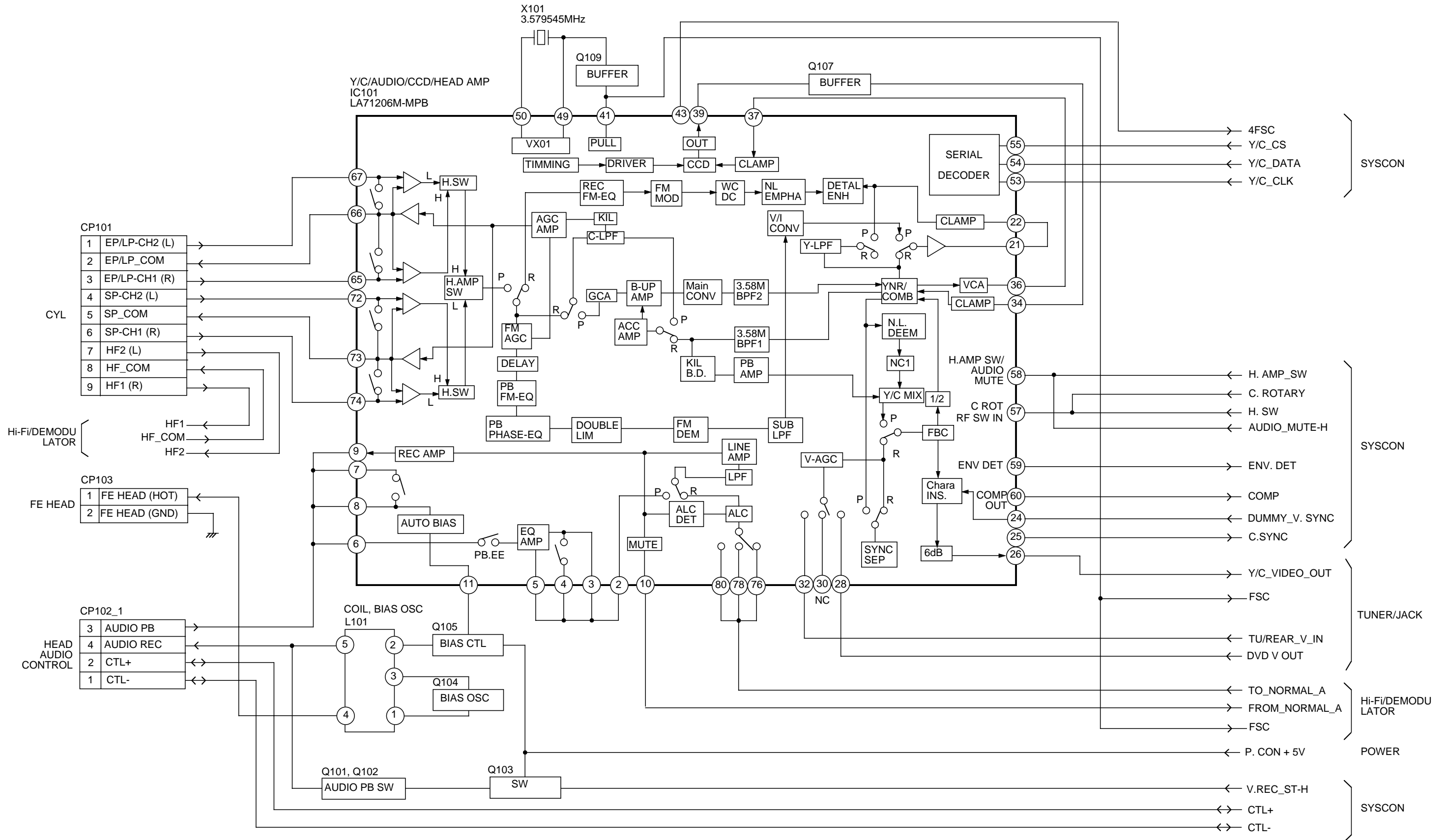

SYSCON BLOCK DIAGRAM

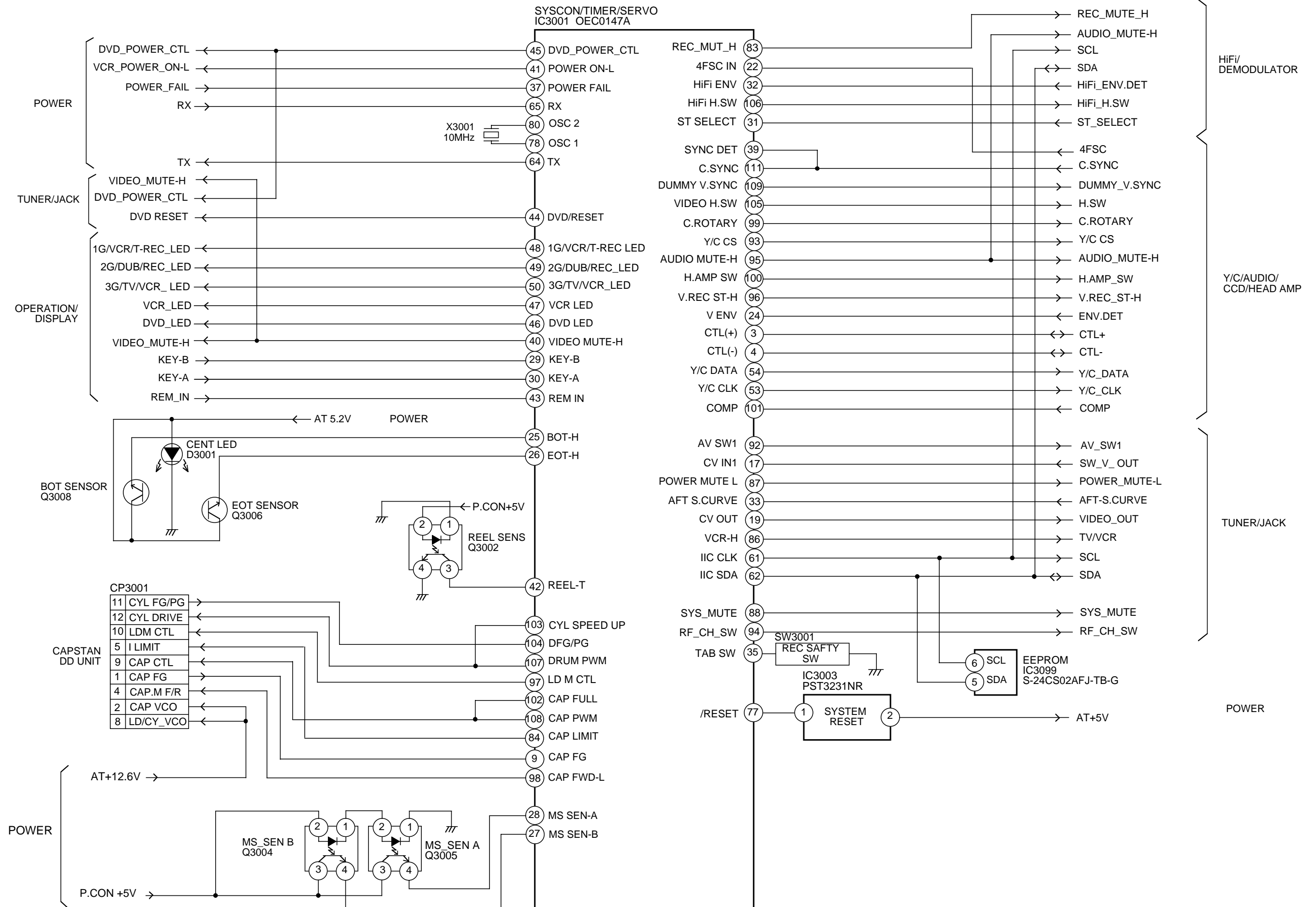

OPERATION/DISPLAY BLOCK DIAGRAM

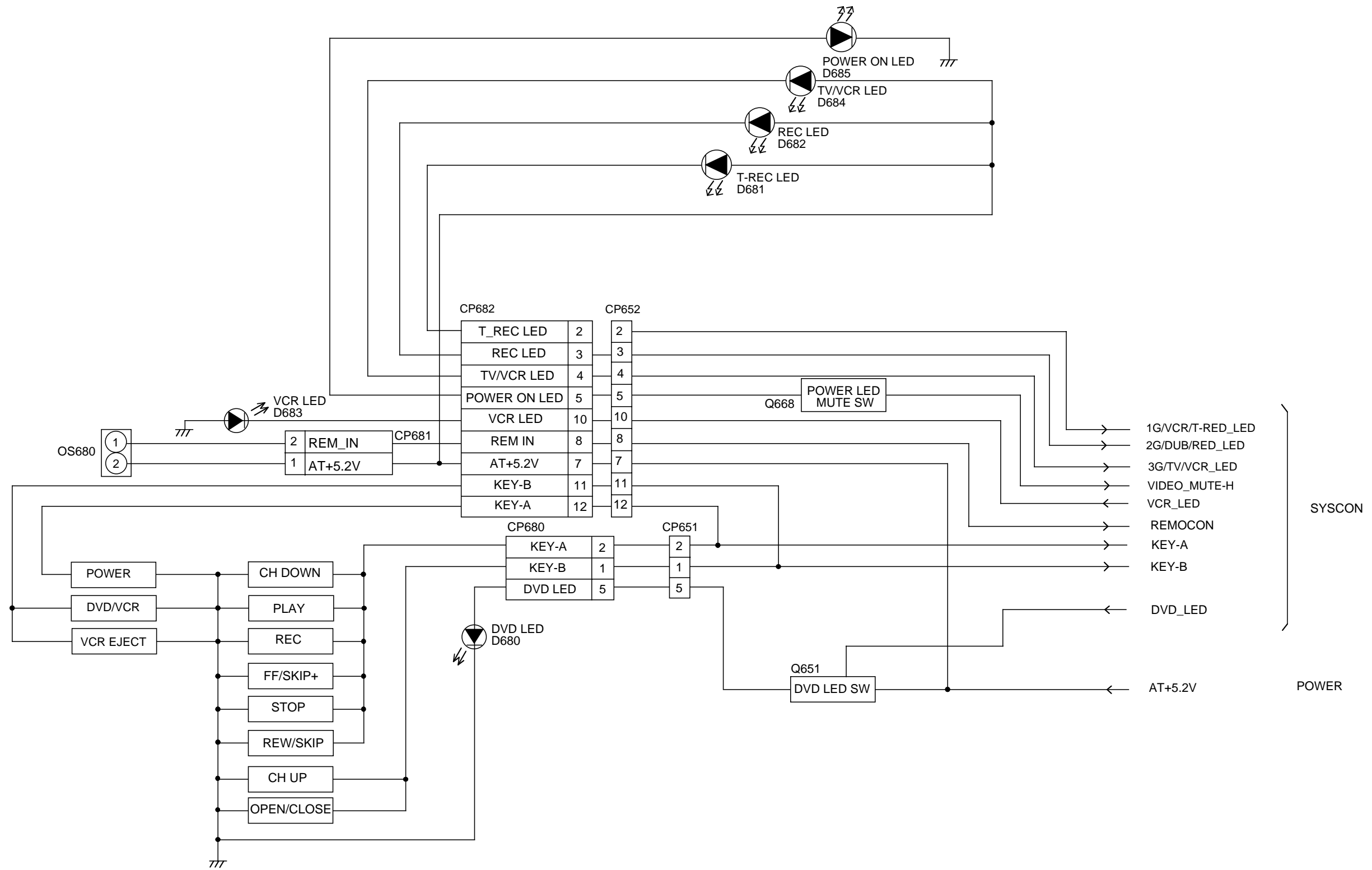

Hi-Fi/DEMODULATOR BLOCK DIAGRAM

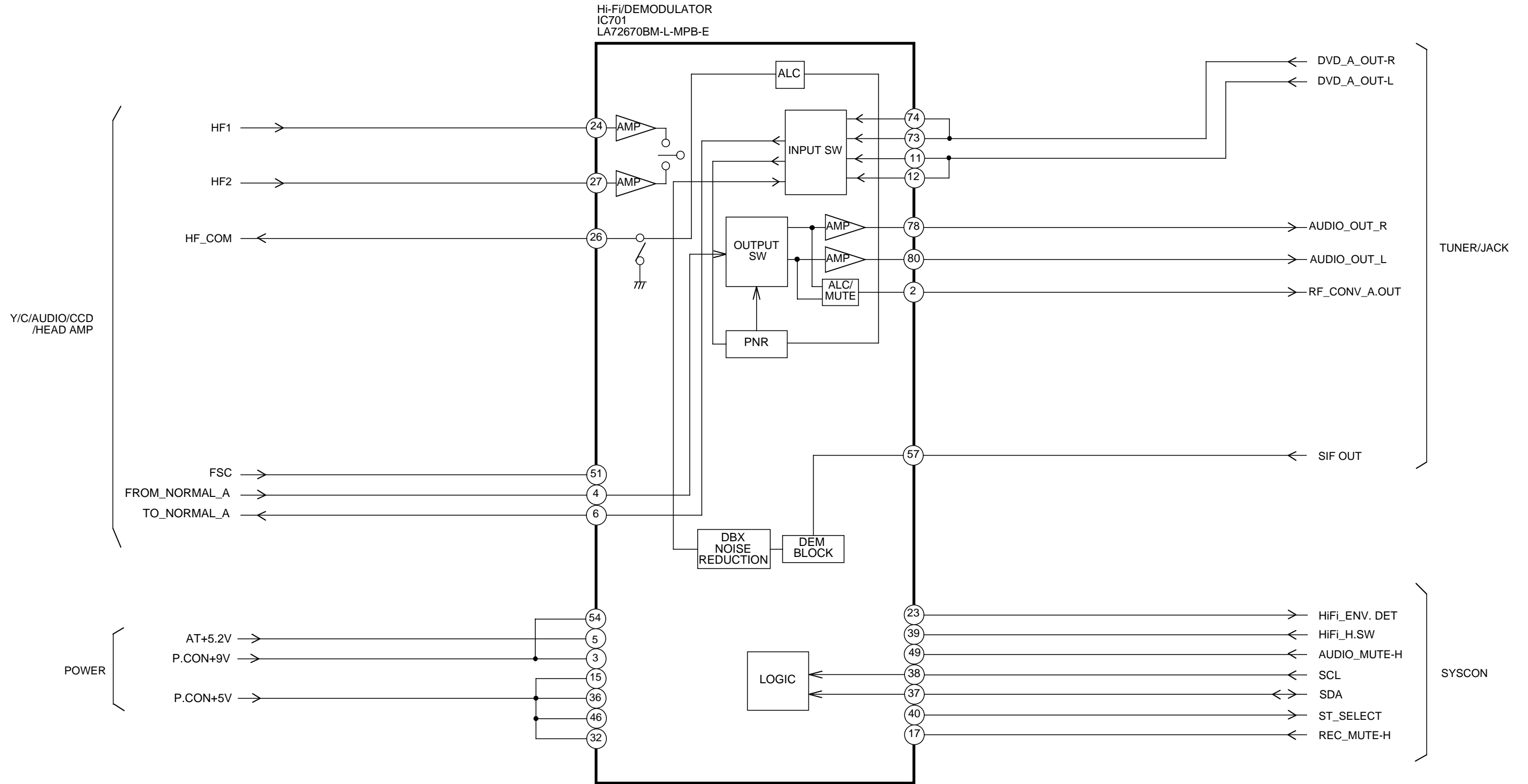

TUNER/JACK BLOCK DIAGRAM

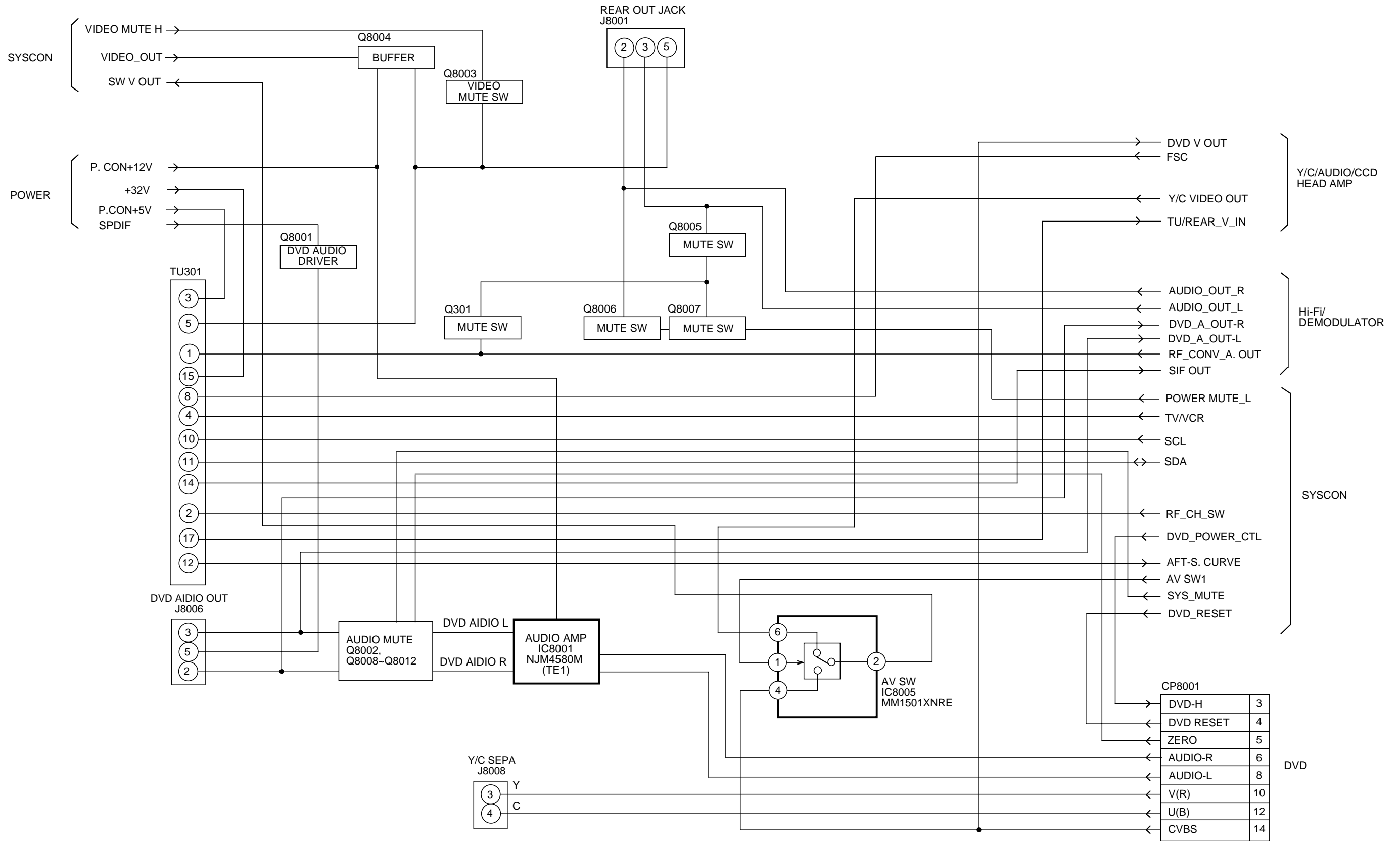

POWER BLOCK DIAGRAM

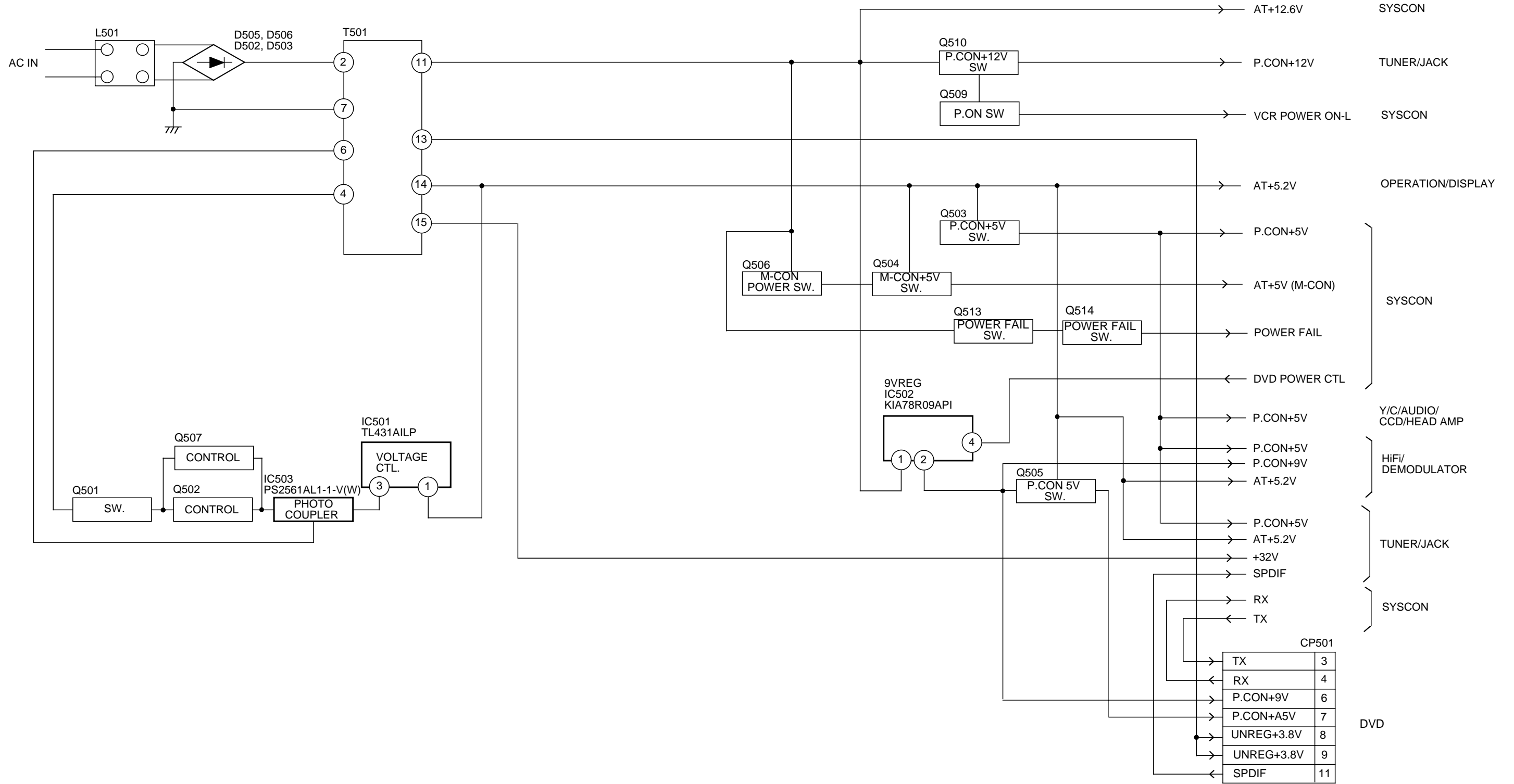

PRINTED CIRCUIT BOARDS

DVD (TOP SIDE)

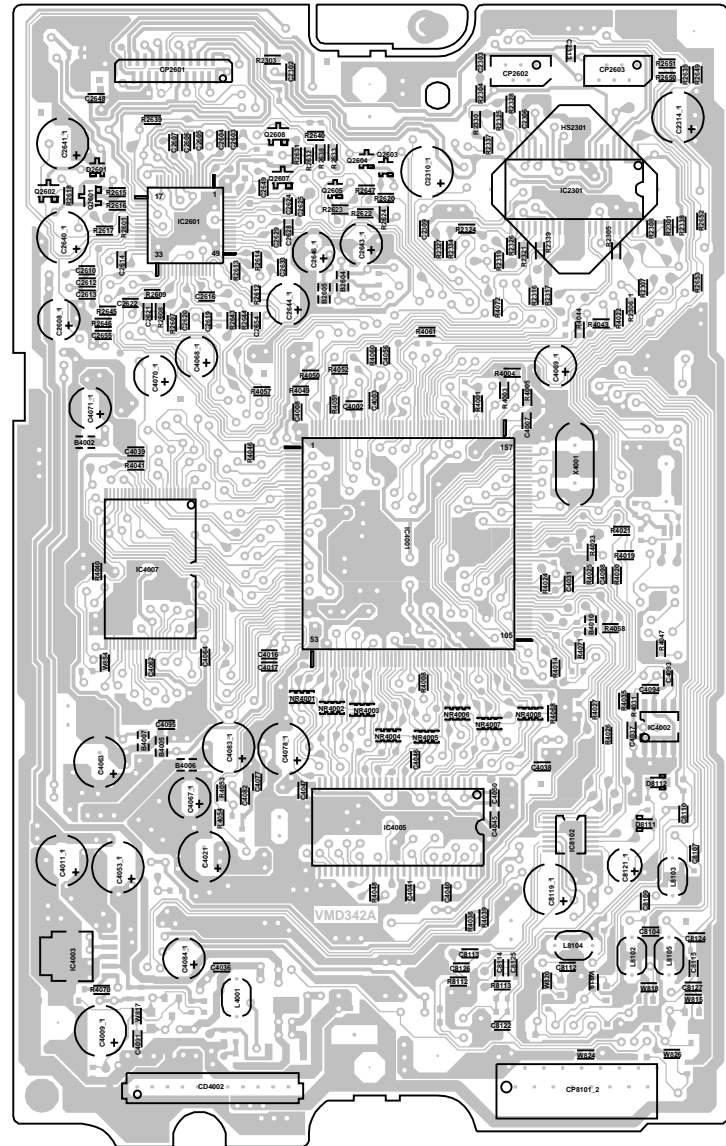

DVD (BOTTOM SIDE)

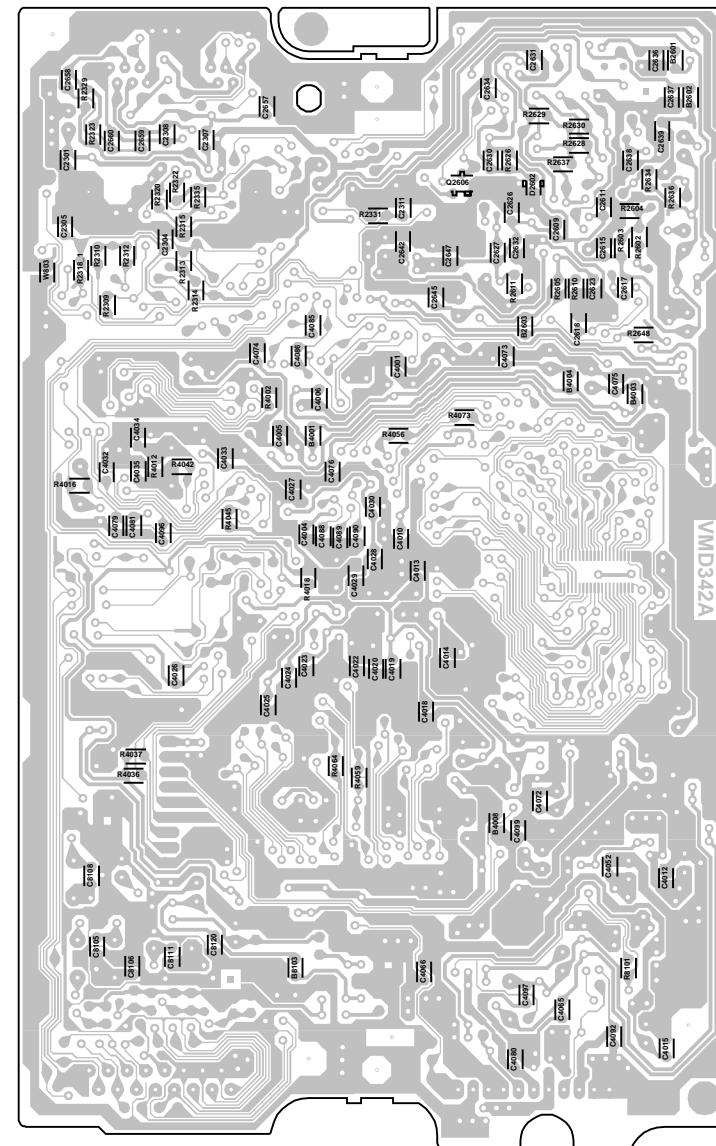

PRINTED CIRCUIT BOARDS
VCR (INSERTED PARTS)
SOLDER SIDE

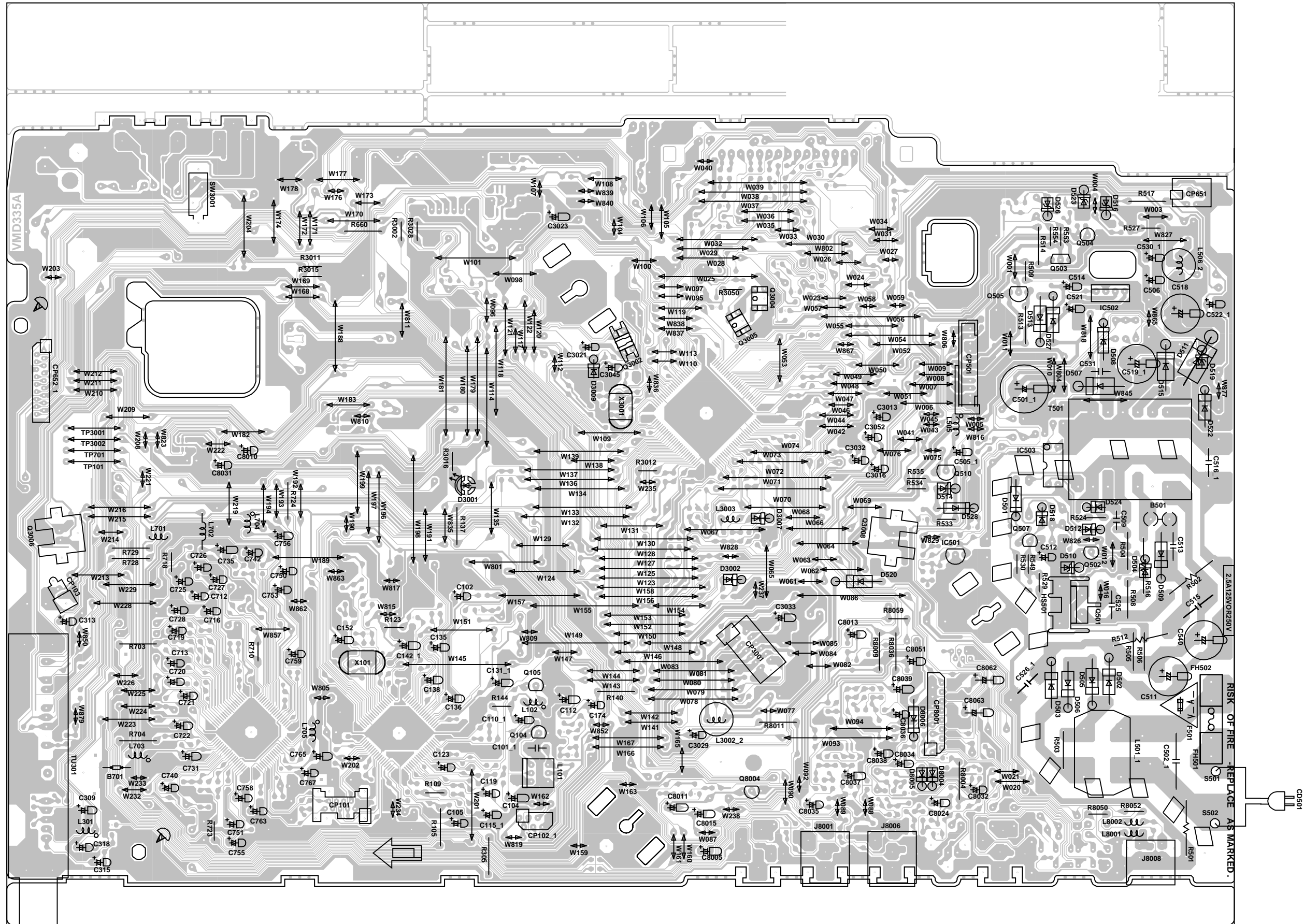

PRINTED CIRCUIT BOARDS
VCR (CHIP MOUNTED PATS)
SOLDER SIDE

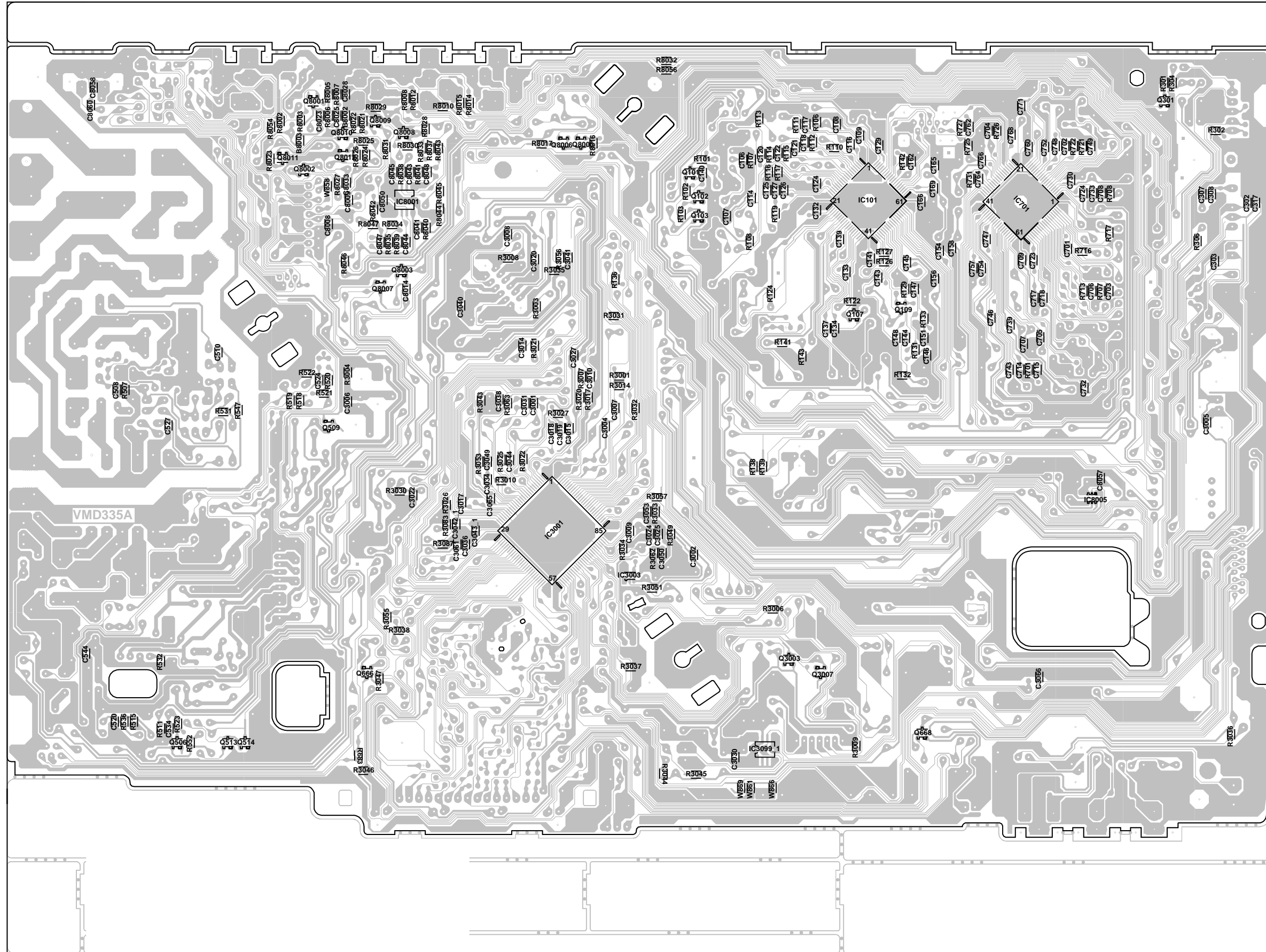

PRINTED CIRCUIT BOARDS

OPERATION 1 SOLDER SIDE

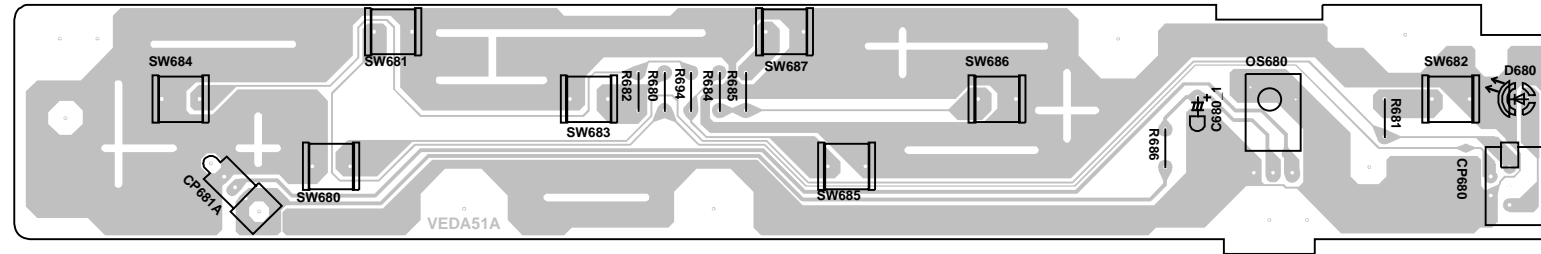

OPERATION 2 SOLDER SIDE

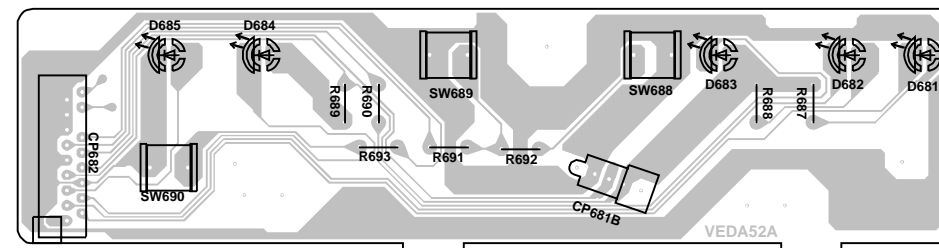

MPEG/MICON/DSP SCHEMATIC DIAGRAM (DVD PCB)

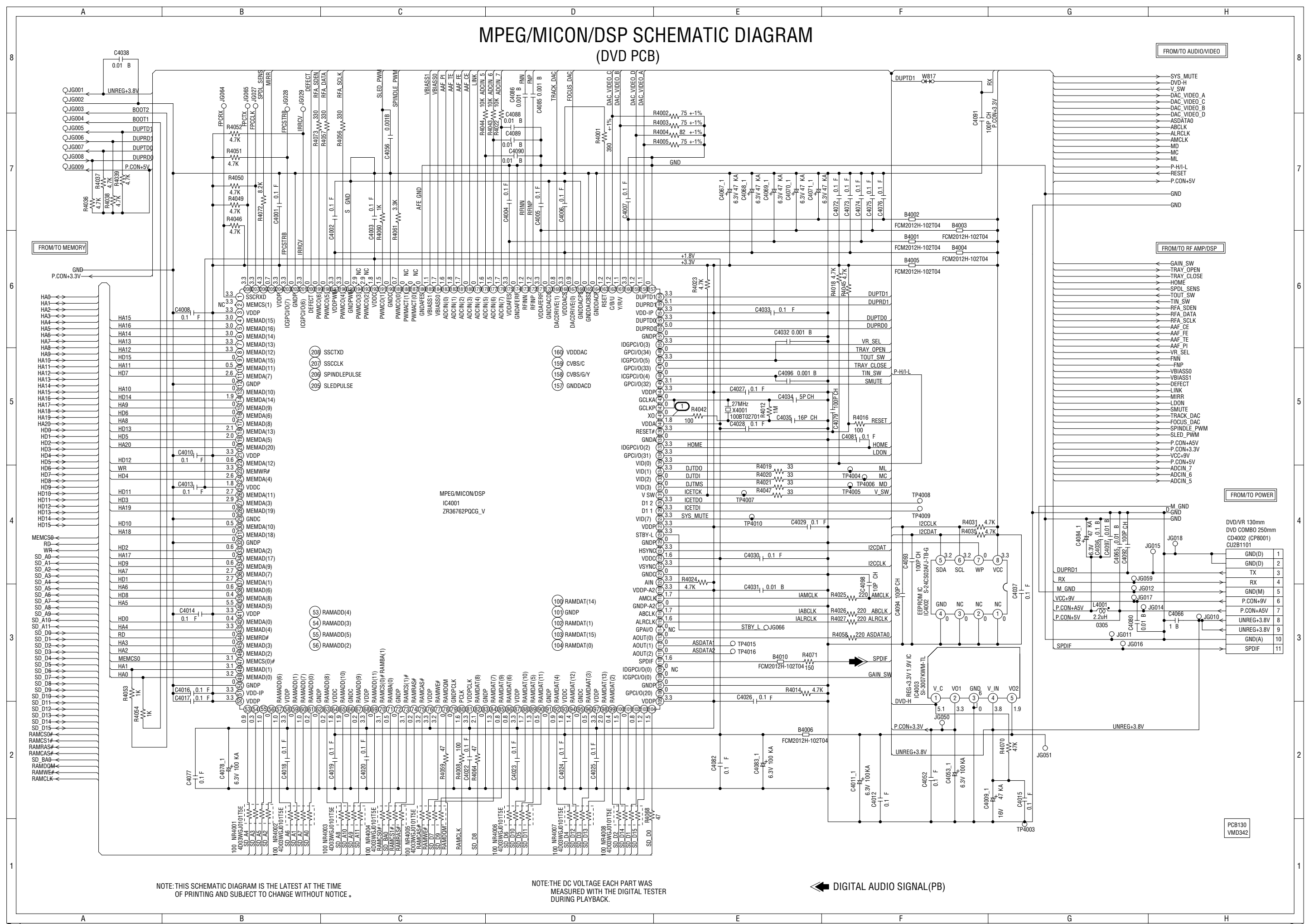

NOTE: THIS SCHEMATIC DIAGRAM IS THE LATEST AT THE TIME OF PRINTING AND SUBJECT TO CHANGE WITHOUT NOTICE.

NOTE: THE DC VOLTAGE EACH PART WAS MEASURED WITH THE DIGITAL TESTER DURING PLAYBACK.

← DIGITAL AUDIO SIGNAL (PB)

PCB130
VMD340

MEMORY SCHEMATIC DIAGRAM (DVD PCB)

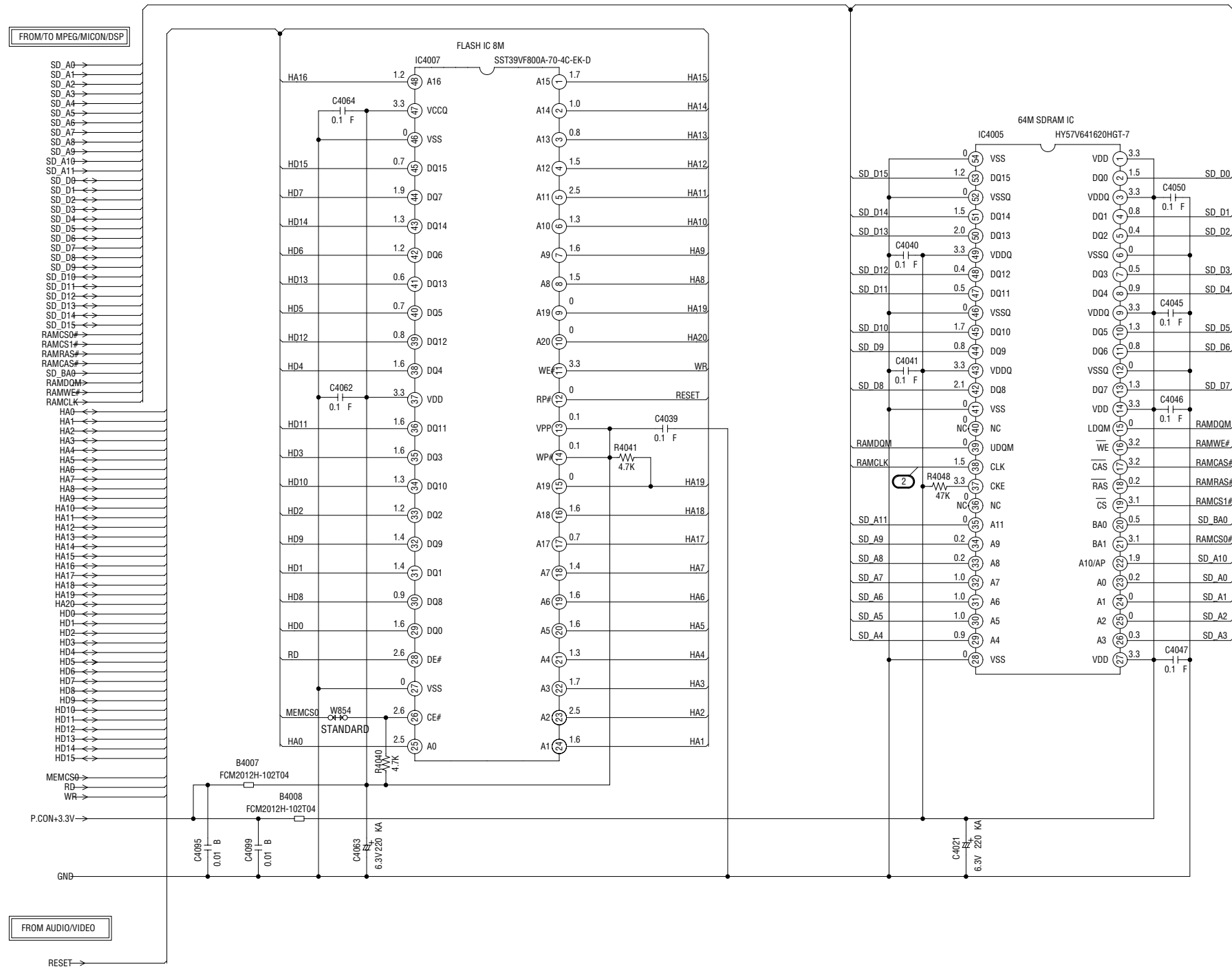

NOTE: THIS SCHEMATIC DIAGRAM IS THE LATEST AT THE TIME OF PRINTING AND SUBJECT TO CHANGE WITHOUT NOTICE.

NOTE: THE DC VOLTAGE EACH PART WAS MEASURED WITH THE DIGITAL TESTER DURING PLAYBACK.

PCB130
VMD342

RF AMP/DSP SCHEMATIC DIAGRAM (DVD PCB)

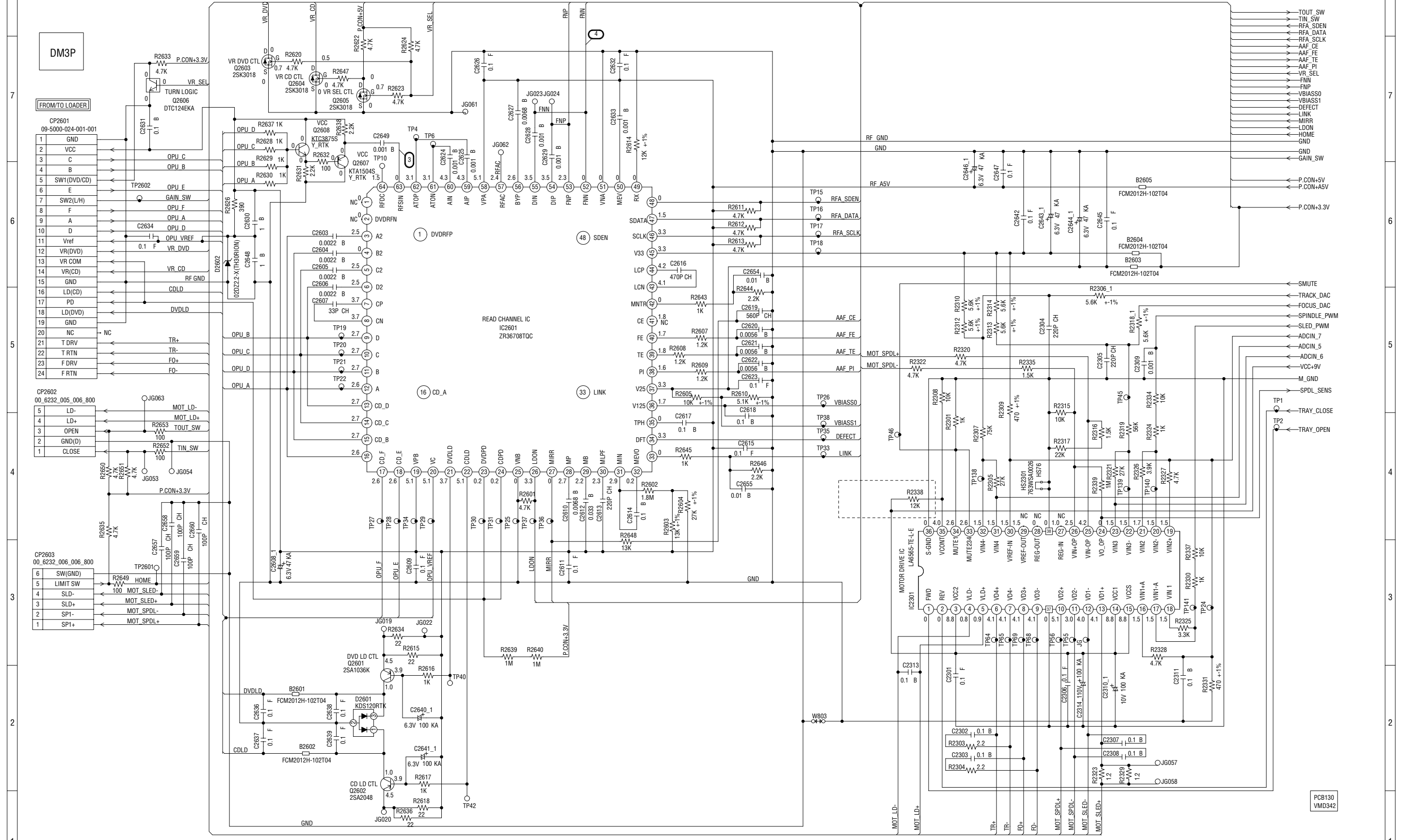

FROM/TO MPEG/MICON/DSP

DM3P

FROM/TO LOADER

CP2601
09-5000-024-001-001

1	GND
2	VCC
3	C
4	B
5	SW1(DVD/CD)
6	E
7	SW2(L/H)
8	F
9	A
10	D
11	Vref
12	VR(DVD)
13	VR COM
14	VR(CD)
15	GND
16	LD(CD)
17	PD
18	LD(DVD)
19	GND
20	NC
21	T DRV
22	T RTN
23	F DRV
24	F RTN

CP2602
00_6232_005_006_800

5	LD-
4	LD+
3	OPEN
2	GND(D)
1	CLOSE

CP2603
00_6232_006_006_800

6	SW(GND)
5	LIMIT SW
4	SLD-
3	SLD+
2	SP1-
1	SP1+

NOTE: THIS SCHEMATIC DIAGRAM IS THE LATEST AT THE TIME OF PRINTING AND SUBJECT TO CHANGE WITHOUT NOTICE.

NOTE: THE DC VOLTAGE EACH PART WAS MEASURED WITH THE DIGITAL TESTER DURING PLAYBACK.

PCB130
VMD342

AUDIO/VIDEO SCHEMATIC DIAGRAM (DVD PCB)

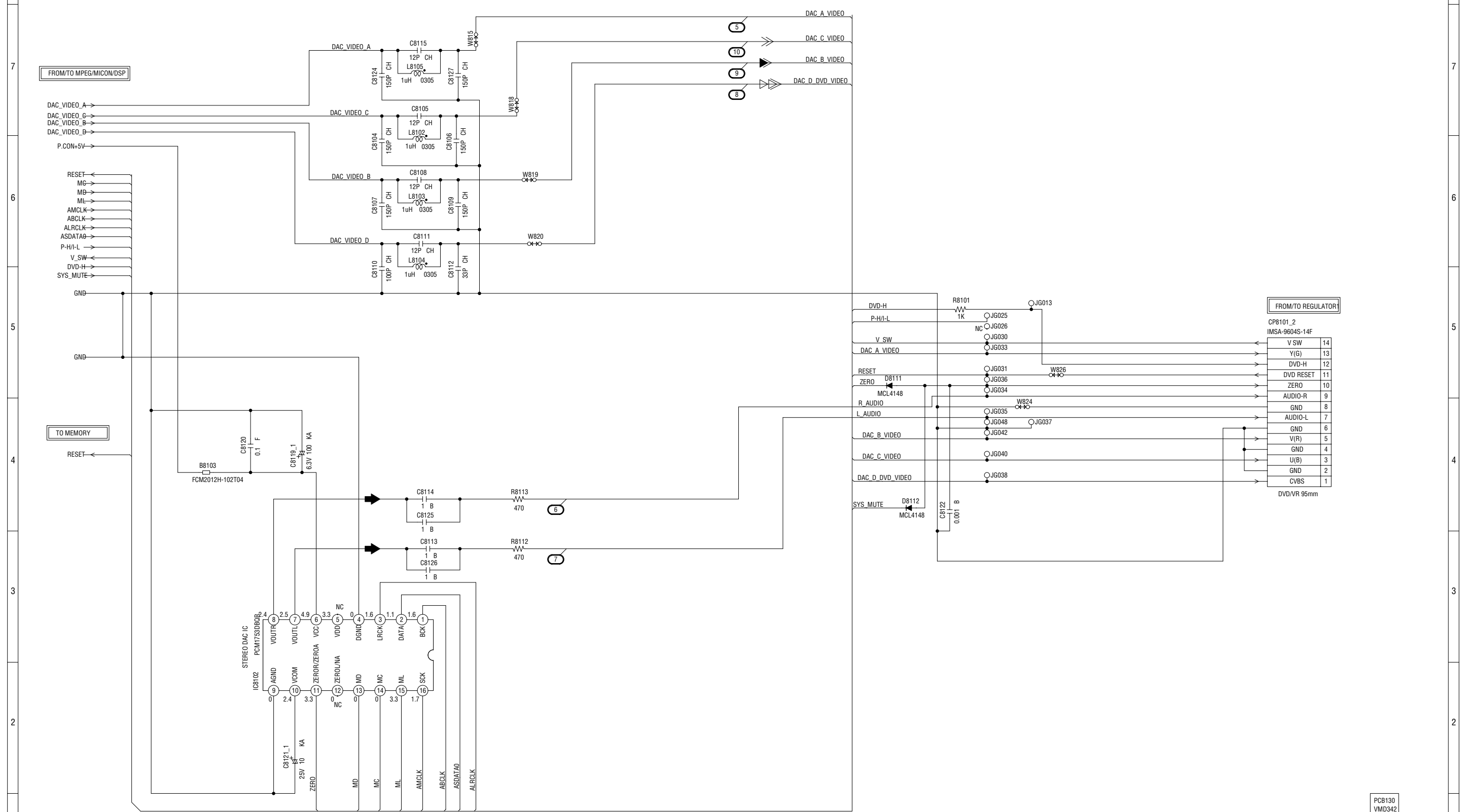

FROM/TO REGULATOR

CP8101_2	IMSA-9604S-14F
V SW	14
Y(G)	13
DVD-H	12
DVD RESET	11
ZERO	10
AUDIO-R	9
GND	8
AUDIO-L	7
GND	6
V(R)	5
GND	4
U(B)	3
GND	2
CVBS	1

DVD/VR 95mm

NOTE: THIS SCHEMATIC DIAGRAM IS THE LATEST AT THE TIME OF PRINTING AND SUBJECT TO CHANGE WITHOUT NOTICE.

NOTE: THE DC VOLTAGE EACH PART WAS MEASURED WITH THE DIGITAL TESTER DURING PLAYBACK.

◀ R.SIGNAL+ COMPONENT SIGNAL(U)
◀ B.SIGNAL+ COMPONENT SIGNAL(V)

◁ PLAYBACK COLOR SIGNAL
◁ PLAYBACK VIDEO SIGNAL
▶ AUDIO SIGNAL(PB)

PCB130
VMD342

Y/C/AUDIO/CCD/HEAD AMP SCHEMATIC DIAGRAM (VCR PCB)

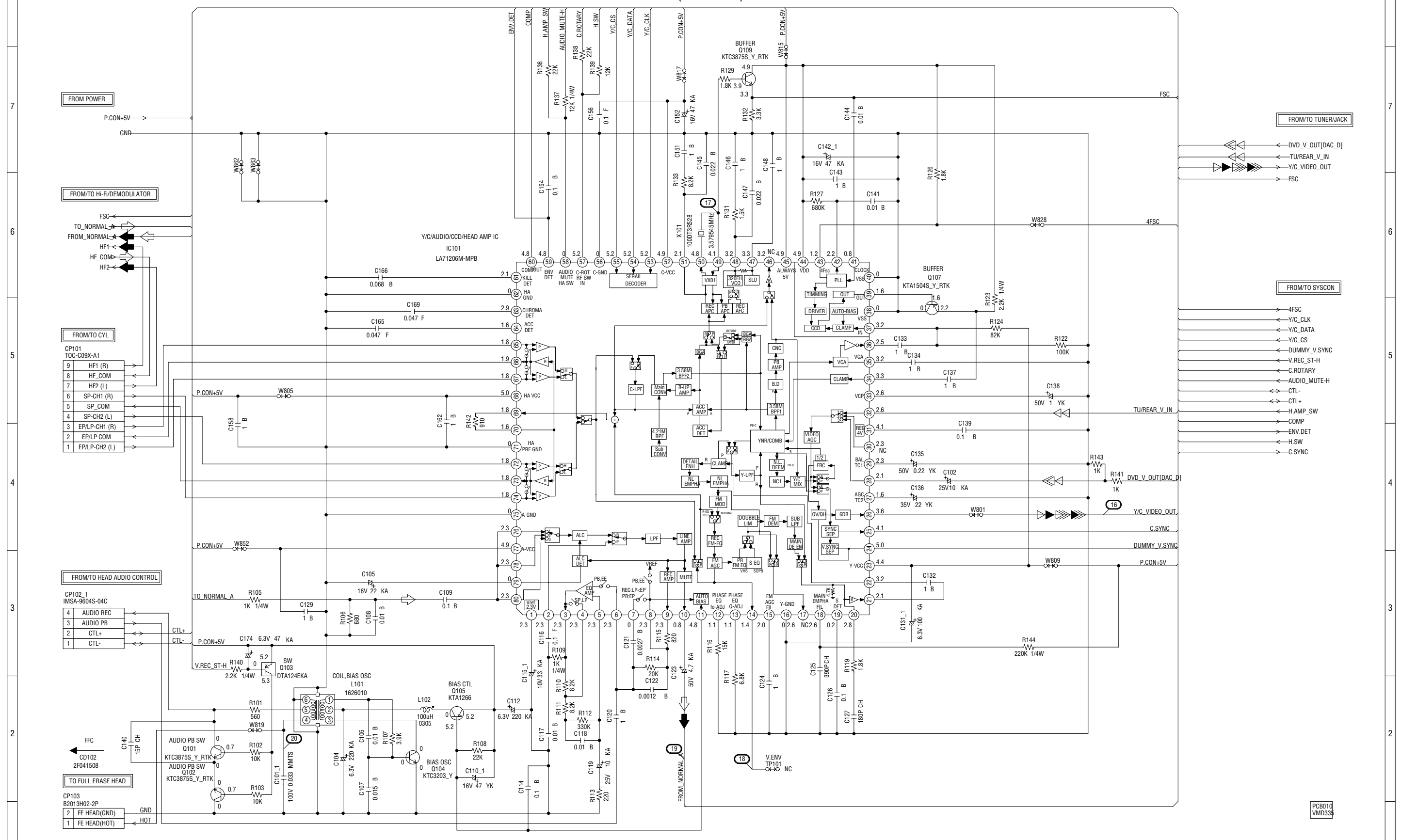

NOTE: THIS SCHEMATIC DIAGRAM IS THE LATEST AT THE TIME OF PRINTING AND SUBJECT TO CHANGE WITHOUT NOTICE.

NOTE: THE DC VOLTAGE EACH PART WAS MEASURED WITH THE DIGITAL TESTER DURING PLAYBACK.

- ◀ AUDIO SIGNAL (REC)
- ▶ RECORD COLOR SIGNAL
- ▶ RECORD LUMINANCE SIGNAL
- ▶▶ PLAYBACK VIDEO SIGNAL
- ▶▶▶ PLAYBACK COLOR SIGNAL
- ▶▶▶▶ PLAYBACK LUMINANCE SIGNAL
- ▶▶▶▶▶ TUNER VIDEO SIGNAL
- ▶▶▶▶▶▶ AUDIO SIGNAL (PB)

CAUTION: DIGITAL TRANSISTOR

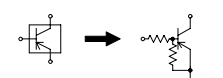

SYSCON SCHEMATIC DIAGRAM (VCR PCB)

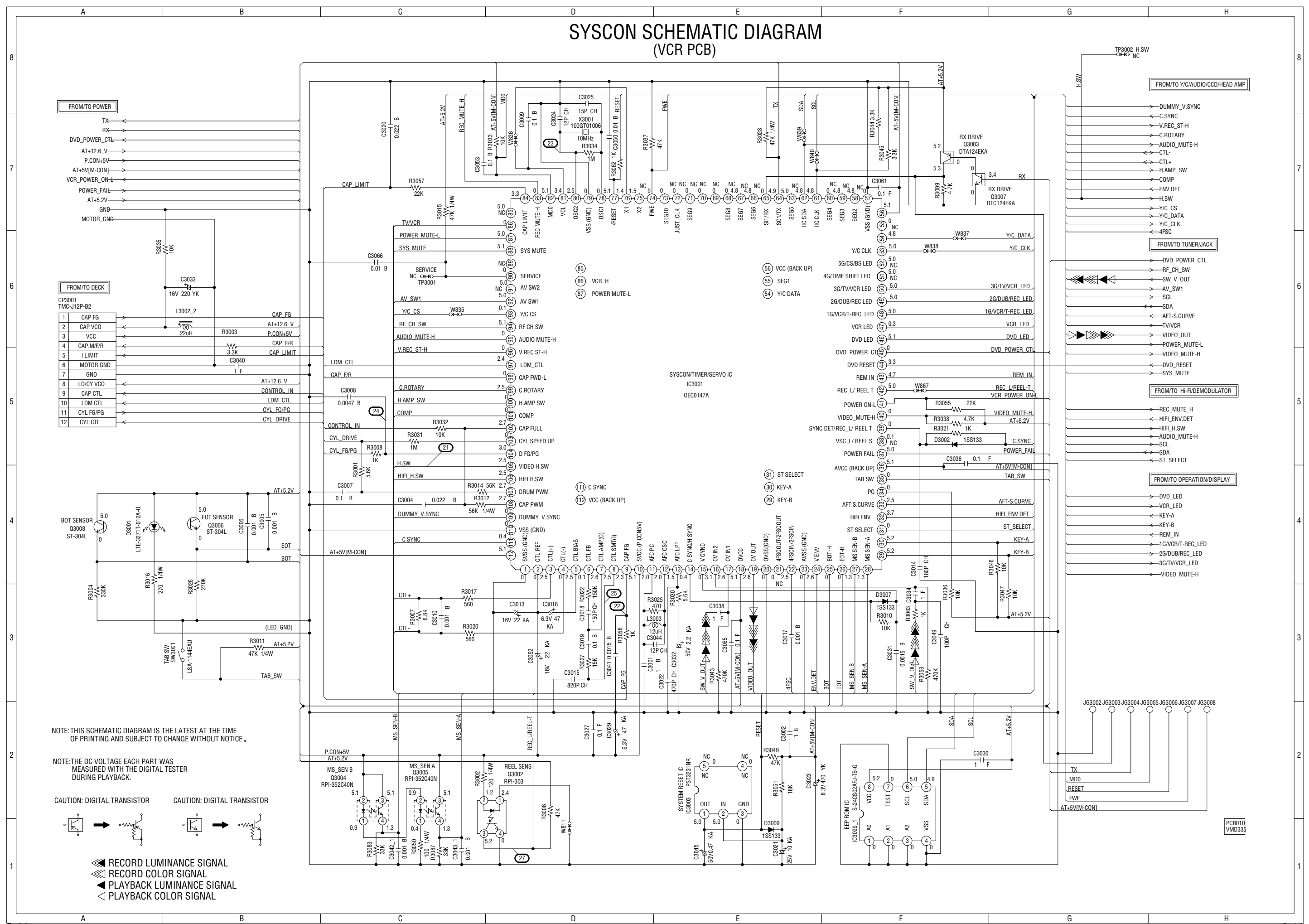

FROM/TO POWER

FROM/TO DECK

NOTE: THIS SCHEMATIC DIAGRAM IS THE LATEST AT THE TIME OF PRINTING AND SUBJECT TO CHANGE WITHOUT NOTICE.

NOTE: THE DC VOLTAGE EACH PART WAS MEASURED WITH THE DIGITAL TESTER DURING PLAYBACK.

CAUTION: DIGITAL TRANSISTOR



- ▶ RECORD LUMINANCE SIGNAL
- ▶▶ RECORD COLOR SIGNAL
- ▶▶▶ PLAYBACK LUMINANCE SIGNAL
- ▶▶▶▶ PLAYBACK COLOR SIGNAL

FROM/TO Y/C/AUDIO/CCD/HEAD AMP

FROM/TO TUNER/JACK

FROM/TO HI-FI/DEMODULATOR

FROM/TO OPERATION/DISPLAY

PCB010 VM0335

TUNER/JACK SCHEMATIC DIAGRAM (VCR PCB)

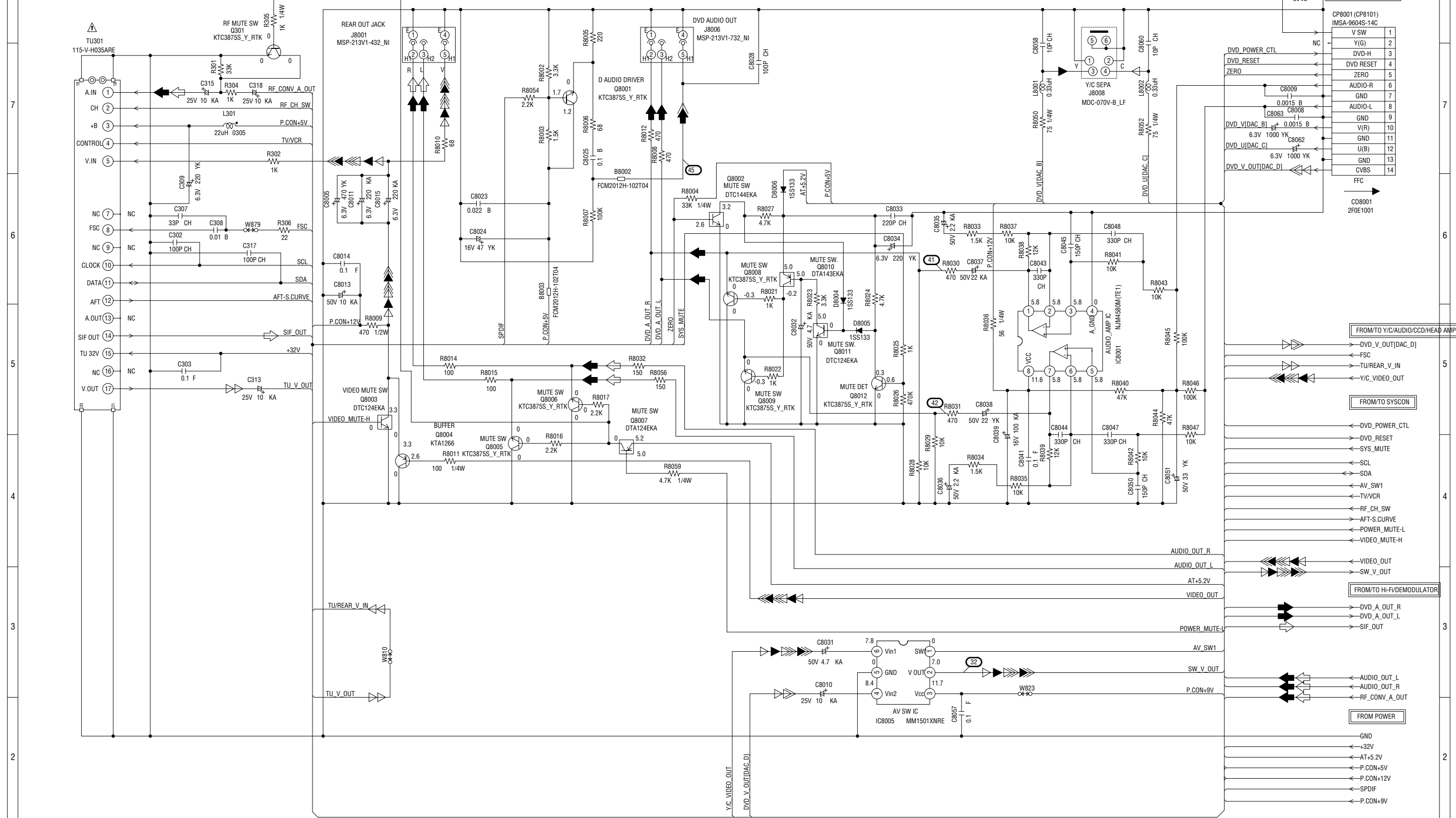

NOTE: THIS SCHEMATIC DIAGRAM IS THE LATEST AT THE TIME OF PRINTING AND SUBJECT TO CHANGE WITHOUT NOTICE.

ATTENTION: LES PIÈCES RÉPARÉES PAR UN ÉTANT DANGEREUSES AN POINT DE VUE SECURITE N'UTILISER QUE CELLS DECRITES DANS LA NOMENCLATURE DES PIÈCES.

CAUTION: SINCE THESE PARTS MARKED BY ARE CRITICAL FOR SAFETY USE ONES DESCRIBED IN PARTS LIST ONLY.

CAUTION: DIGITAL TRANSISTOR

CAUTION: DIGITAL TRANSISTOR

RECORD COLOR SIGNAL
 RECORD LUMINANCE SIGNAL
 PLAYBACK VIDEO SIGNAL
 TUNER VIDEO SIGNAL

PLAYBACK LUMINANCE SIGNAL
 PLAYBACK COLOR SIGNAL
 AUDIO SIGNAL(REC)
 AUDIO SIGNAL(PB)

NOTE: THE DC VOLTAGE EACH PART WAS MEASURED WITH THE DIGITAL TESTER DURING PLAYBACK.

PCB010
VMD333

OPERATION/DISPLAY SCHEMATIC DIAGRAM (VCR PCB)

FROM/TO OPERATION 2

CP652_1 (CP601)
00_6232_018_006_800

18	NC
17	GND
16	NC
15	GND
14	NC
13	GND
12	KEY-A
11	KEY-B
10	VCR_LED
9	GND
8	REM_IN
7	AT+5.2V
6	GND
5	POWER ON LED
4	TV/VCR_LED
3	REC_LED
2	T-REC_LED
1	DVD_LED

KEY-A
KEY-B
VCR_LED
REM_IN
AT+5.2V
P.CON+5V
3G/TV/VCR_LED
2G/DUB/REC_LED
1G/VCR/T-REC_LED
VIDEO_MUTE-H
0 POWER LED NUTE SW Q668 DTC124EKA

FROM/TO SYSCON

DVD_LED
VCR_LED
1G/VCR/T-REC_LED
2G/DUB/REC_LED
3G/TV/VCR_LED
REM_IN
KEY-B
KEY-A
VIDEO_MUTE-H

FROM POWER

GND
P.CON+5V
AT+5.2V

FROM/TO OPERATION/LED

CP651 (CP681) MNSA-9804S-06F
DVD_LED
GND
KEY-A
KEY-B

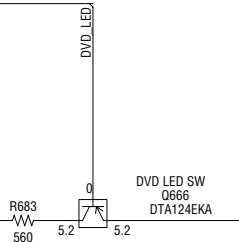

W802

W861

W866

W869

KEY-B

PCB010
VMD333

NOTE: THIS SCHEMATIC DIAGRAM IS THE LATEST AT THE TIME OF PRINTING AND SUBJECT TO CHANGE WITHOUT NOTICE.

NOTE: THE DC VOLTAGE EACH PART WAS MEASURED WITH THE DIGITAL TESTER DURING PLAYBACK.

CAUTION: DIGITAL TRANSISTOR

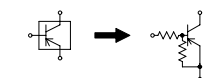

CAUTION: DIGITAL TRANSISTOR

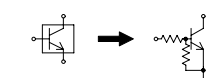

- ← AUDIO SIGNAL (REC)
- ≡ RECORD COLOR SIGNAL
- ◀ RECORD LUMINANCE SIGNAL

Hi-Fi/DEMODULATOR SCHEMATIC DIAGRAM (VCR PCB)

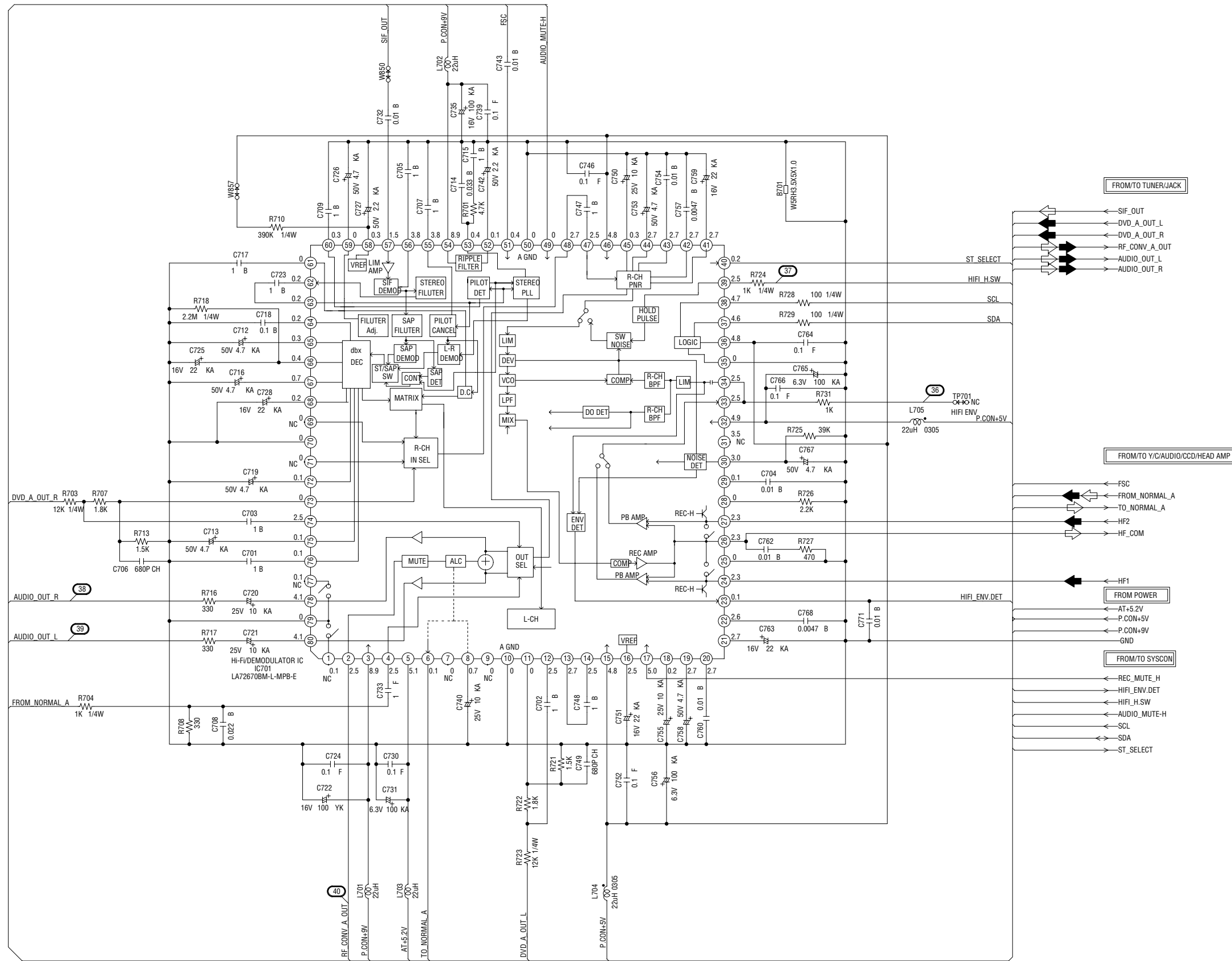

NOTE: THIS SCHEMATIC DIAGRAM IS THE LATEST AT THE TIME OF PRINTING AND SUBJECT TO CHANGE WITHOUT NOTICE.

NOTE: THE DC VOLTAGE EACH PART WAS MEASURED WITH THE DIGITAL TESTER DURING PLAYBACK.

◁ AUDIO SIGNAL (REC)
 ◀ AUDIO SIGNAL (PB)

PCB010
VMD335

POWER SCHEMATIC DIAGRAM (VCR PCB)

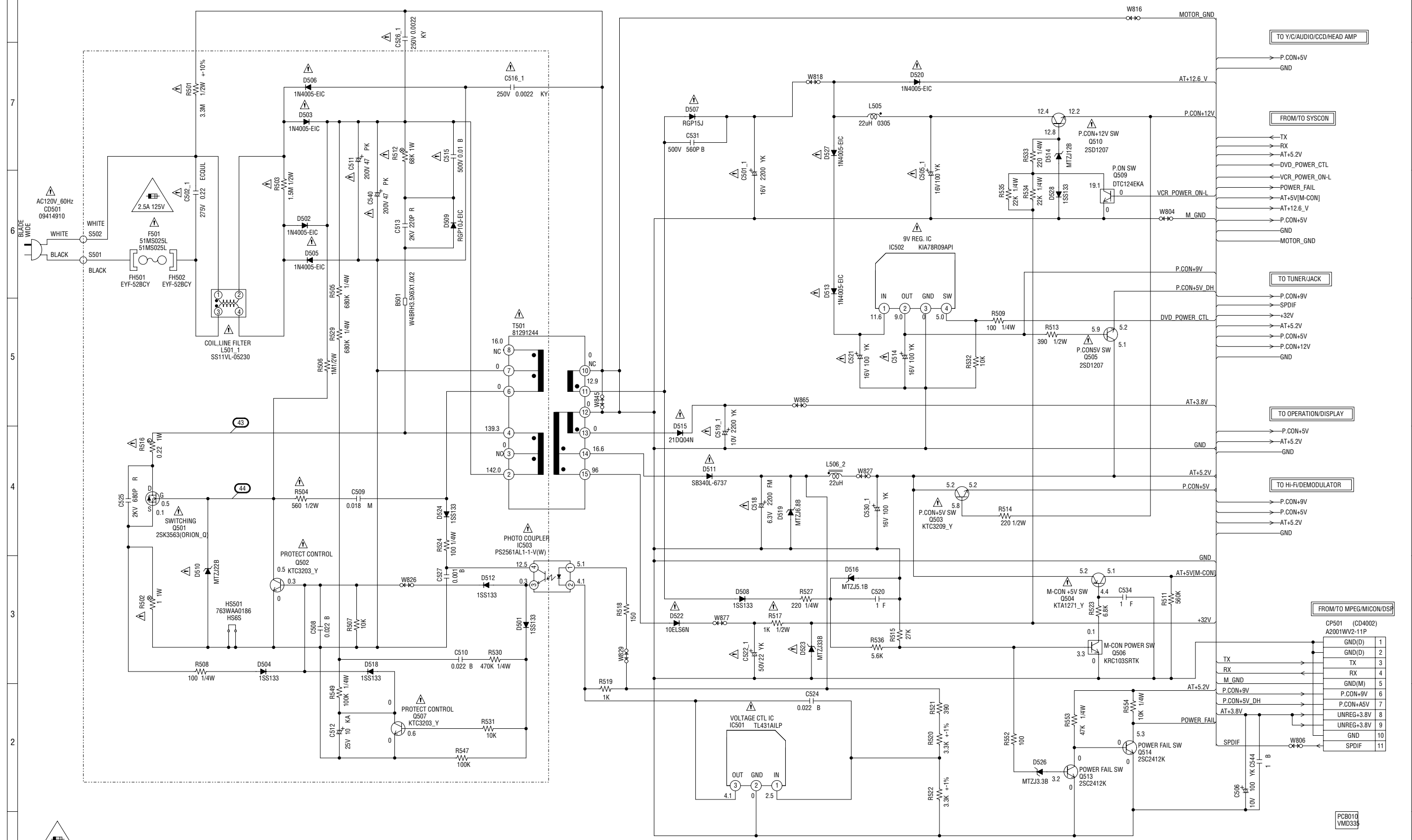

CAUTION :FOR CONTINUED PROTECTION AGAINST FIRE HAZARD, REPLACE ONLY WITH THE SAME TYPE FUSE 2.5A 125V(F501).

ATTENTION :POUR UNE PROTECTION CONTINUE LES RISQUES D'INCEIE N'UTILISER QUE DES FUSIBLE DE MEME TYPE 2.5A 125V(F501).

NOTE: THIS SCHEMATIC DIAGRAM IS THE LATEST AT THE TIME OF PRINTING AND SUBJECT TO CHANGE WITHOUT NOTICE.

NOTE: THE DC VOLTAGE EACH PART WAS MEASURED WITH THE DIGITAL TESTER DURING PLAYBACK.

ATTENTION :LES PIECES REPARÉES PAR UN ETANT DANGEREUSES AN POINT DE VUE SECURITE N'UTILISER QUE CELLES DECRITES DANS LA NOMENCLATURE DES PIECES.

CAUTION :SINCE THESE PARTS MARKED BY ARE CRITICAL FOR SAFETY, USE ONES DESCRIBED IN PARTS LIST ONLY.

CAUTION: DIGITAL TRANSISTOR

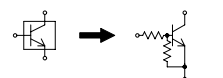

CP501 (CD4002) A2001WV2-11P	
GND(D)	1
GND(D)	2
TX	3
RX	4
M_GND	5
P.CON+9V	6
P.CON+5V_DH	7
P.CON+5V	8
UNREG+3.8V	9
UNREG+3.8V	9
GND	10
SPDIF	11

OPERATION 1 SCHEMATIC DIAGRAM

(OPERATION 1 PCB)

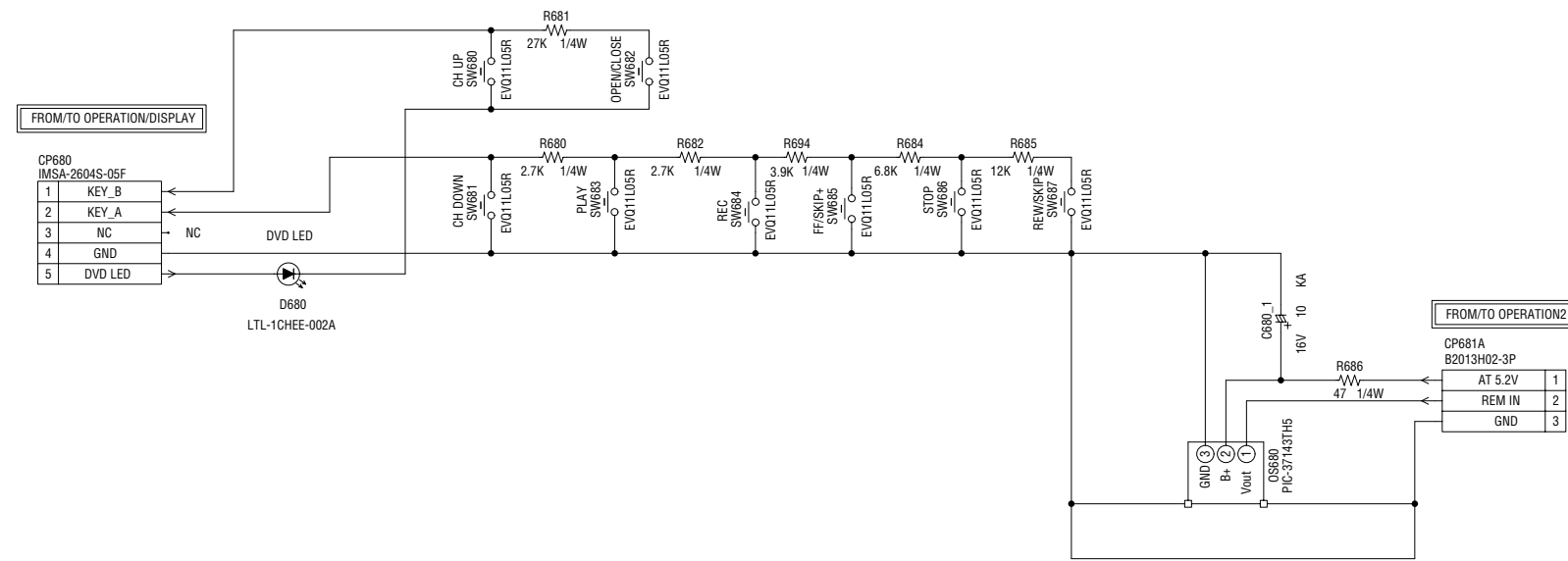

PCB270
VEDA51

OPERATION 2 SCHEMATIC DIAGRAM (OPERATION 2 PCB)

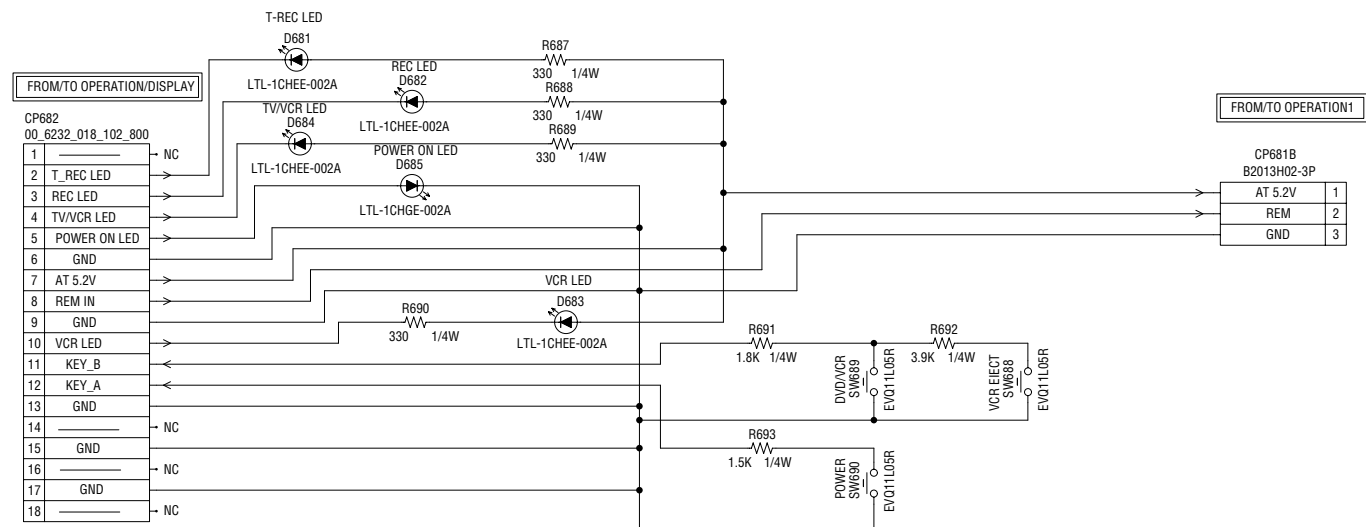

PCB270
VEDA52

INTERCONNECTION DIAGRAM

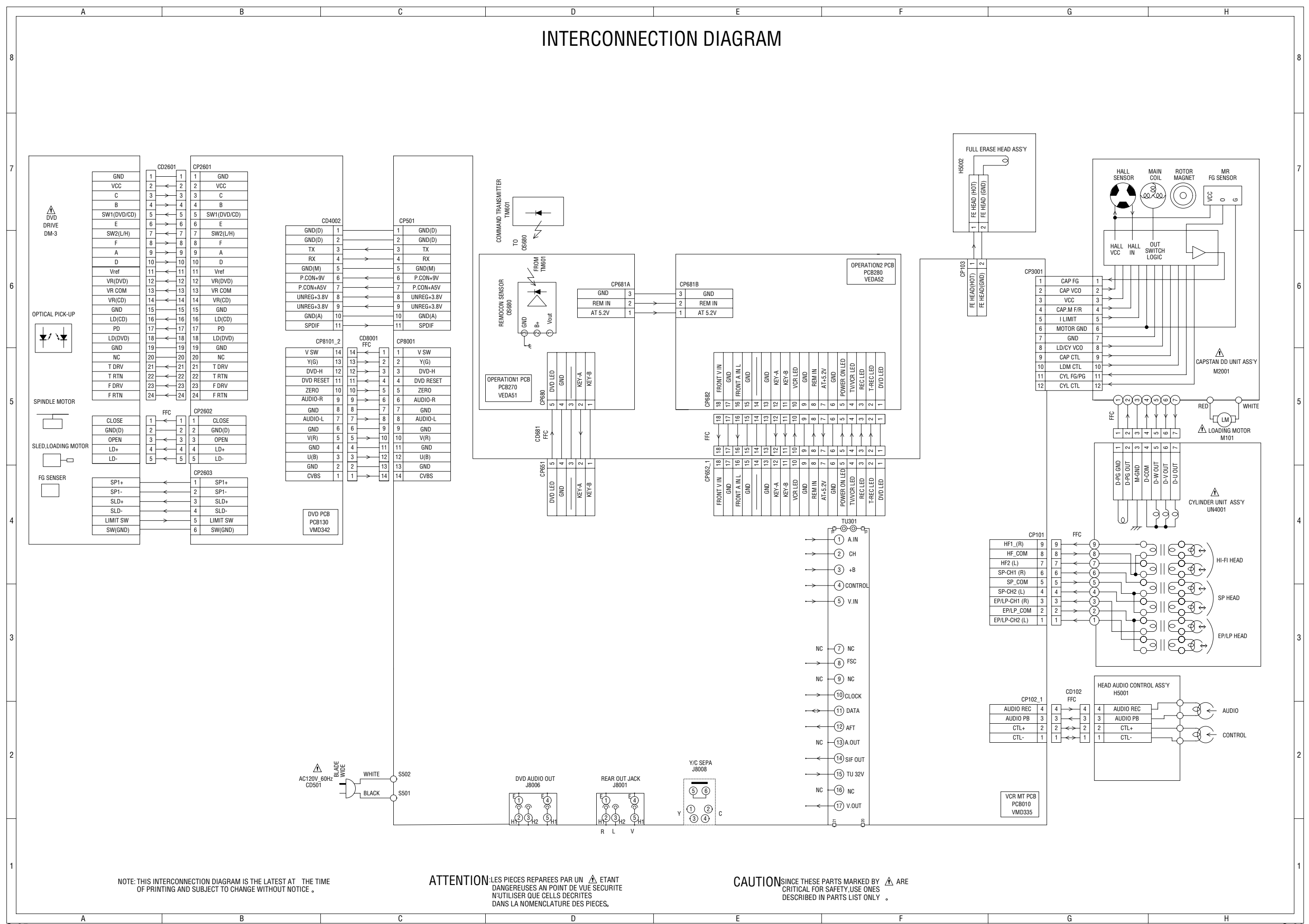

NOTE: THIS INTERCONNECTION DIAGRAM IS THE LATEST AT THE TIME OF PRINTING AND SUBJECT TO CHANGE WITHOUT NOTICE.

ATTENTION - LES PIÈCES RÉPARÉES PAR UN ÉTANT DANGEREUSES AU POINT DE VUE SÉCURITÉ, N'UTILISER QUE CELLES DÉCRITES DANS LA NOMENCLATURE DES PIÈCES.

CAUTION - SINCE THESE PARTS MARKED BY ARE CRITICAL FOR SAFETY, USE ONES DESCRIBED IN PARTS LIST ONLY.

WAVEFORMS

MPEG/MICON/DSP

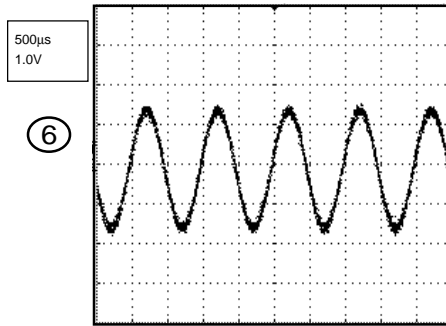
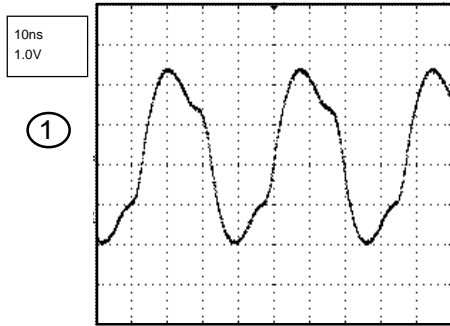

MEMORY

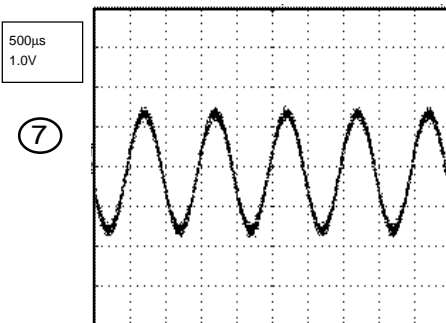
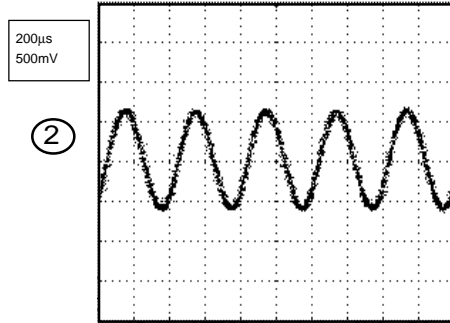

RF AMP/DSP

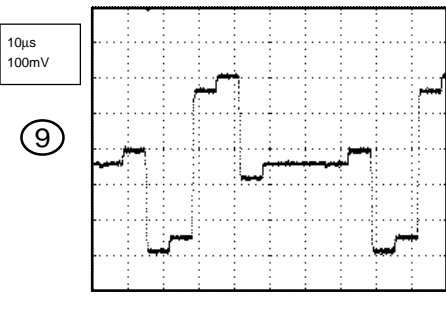
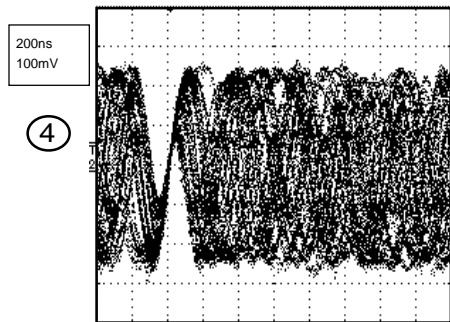
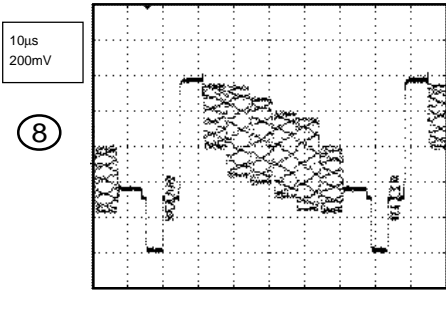
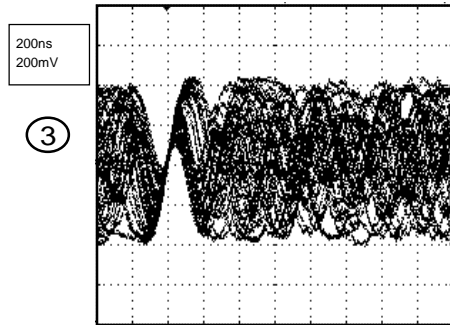

AUDIO/VIDEO

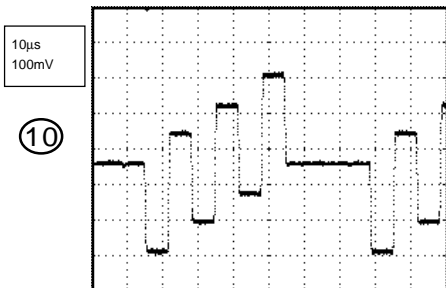
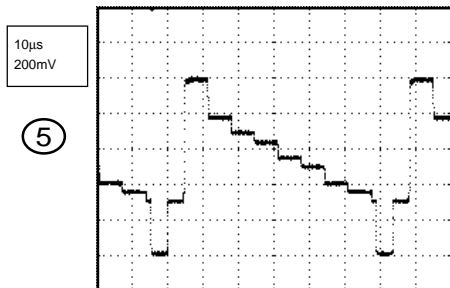

Y/C/AUDIO/CCD/HEAD AMP

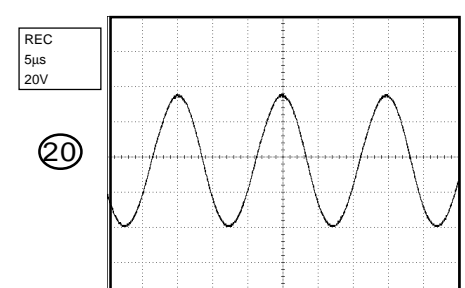
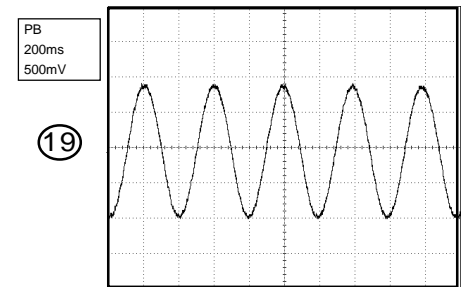
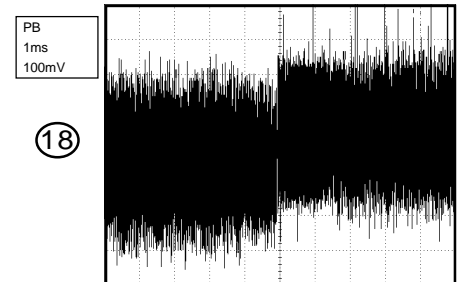
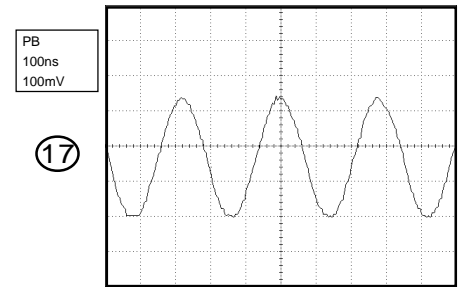
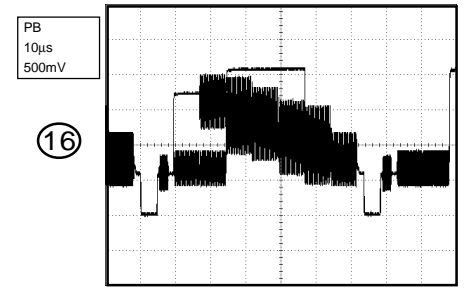

NOTE: The following waveforms were measured at the point of the corresponding balloon number in the schematic diagram.

WAVEFORMS

SYSCON

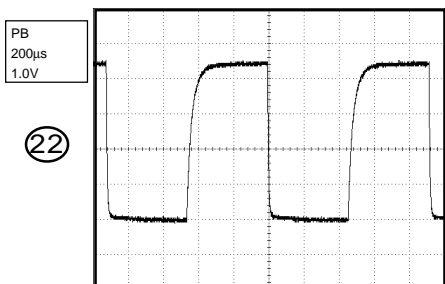
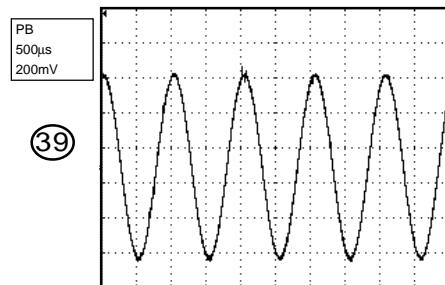
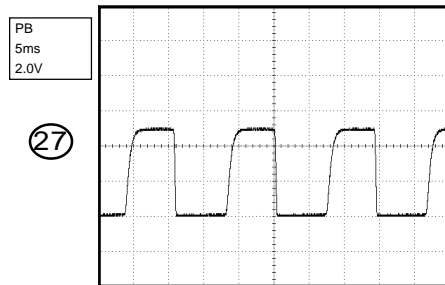
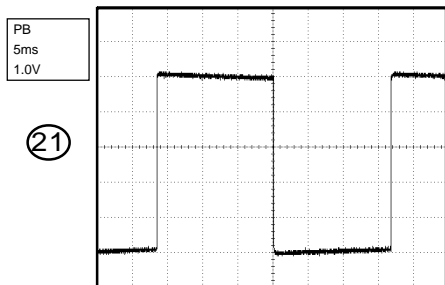

TUNER/JACK

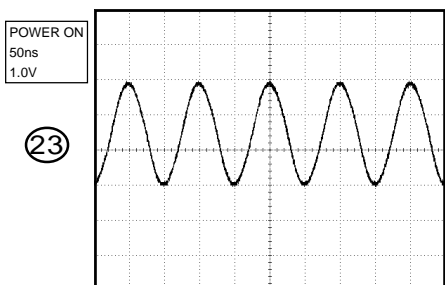
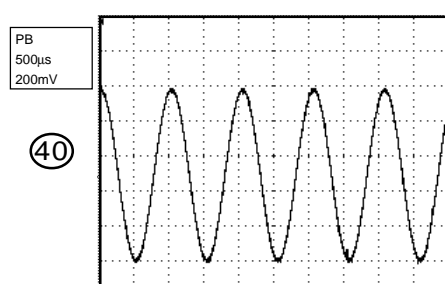
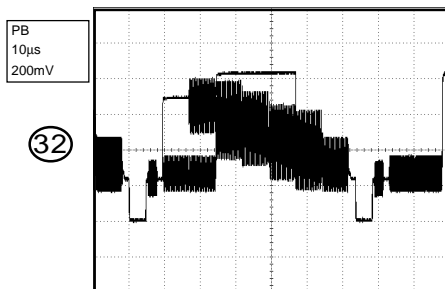

Hi-Fi/DEMODULATOR

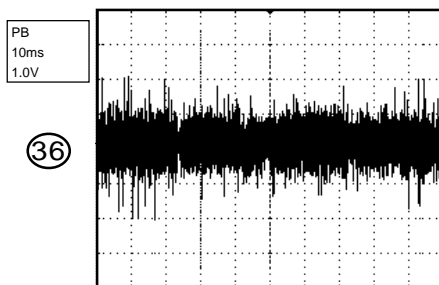

TUNER/JACK

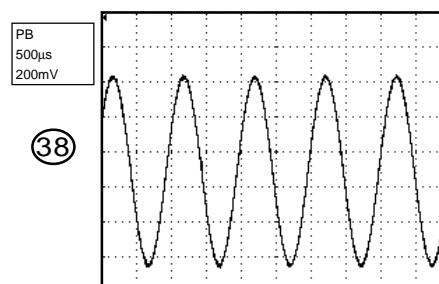
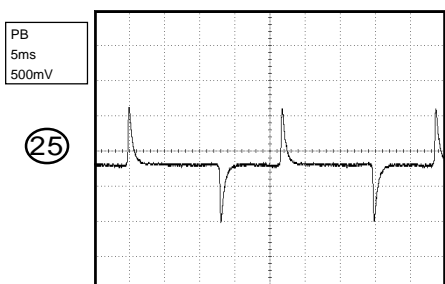
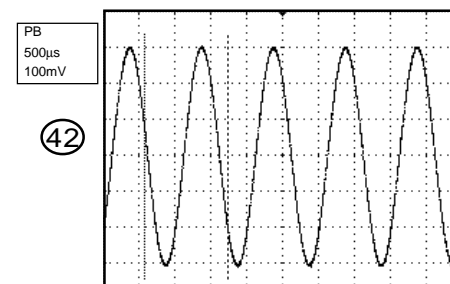
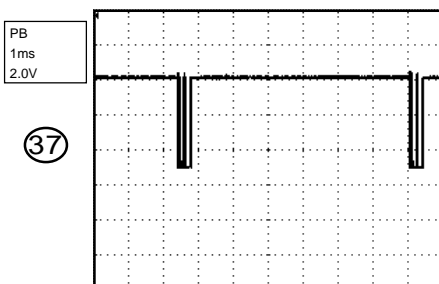
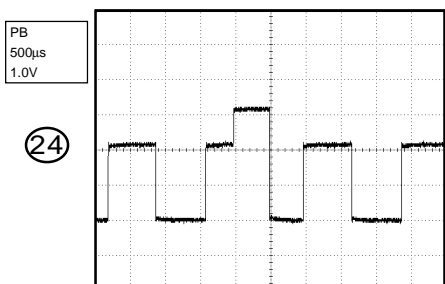
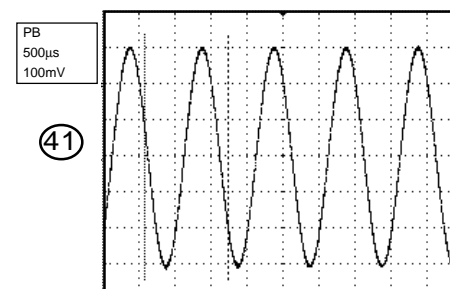

POWER

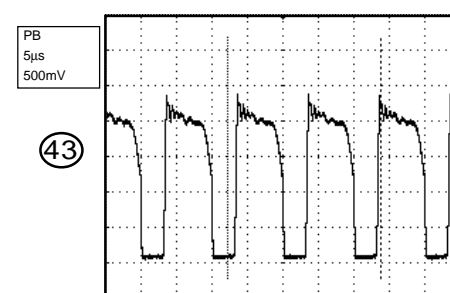

NOTE: The following waveforms were measured at the point of the corresponding balloon number in the schematic diagram.

WAVEFORMS

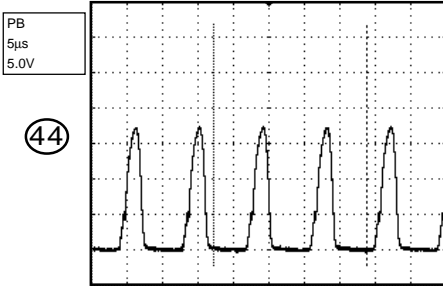

TUNER/JACK

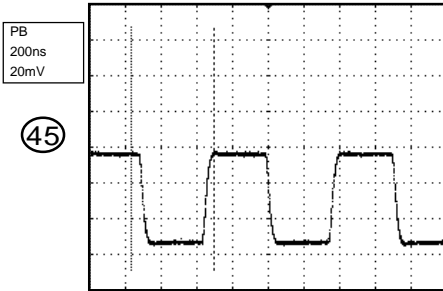

NOTE: The following waveforms were measured at the point of the corresponding balloon number in the schematic diagram.

MECHANICAL EXPLODED VIEW

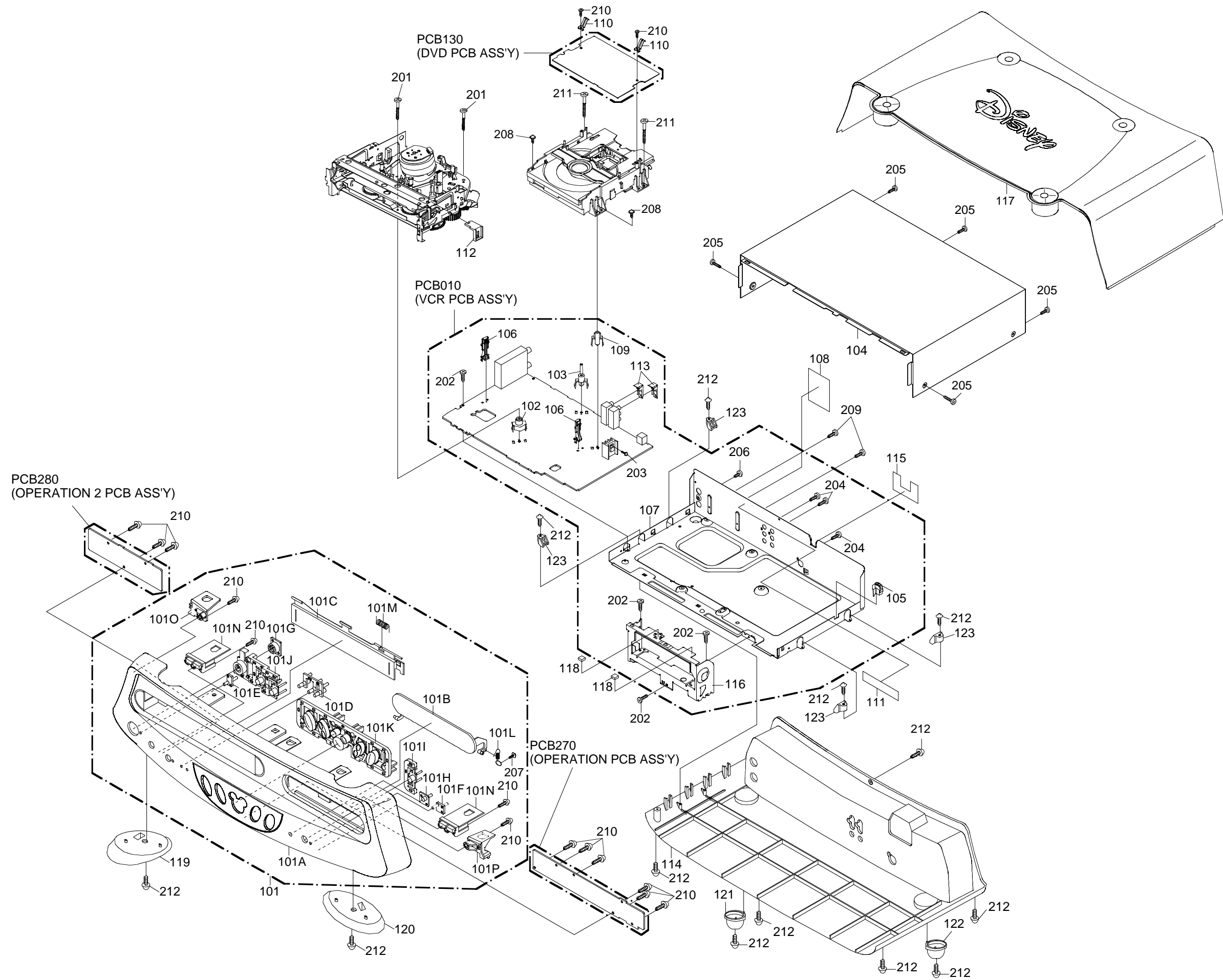

CHASSIS EXPLODED VIEW (TOP VIEW)

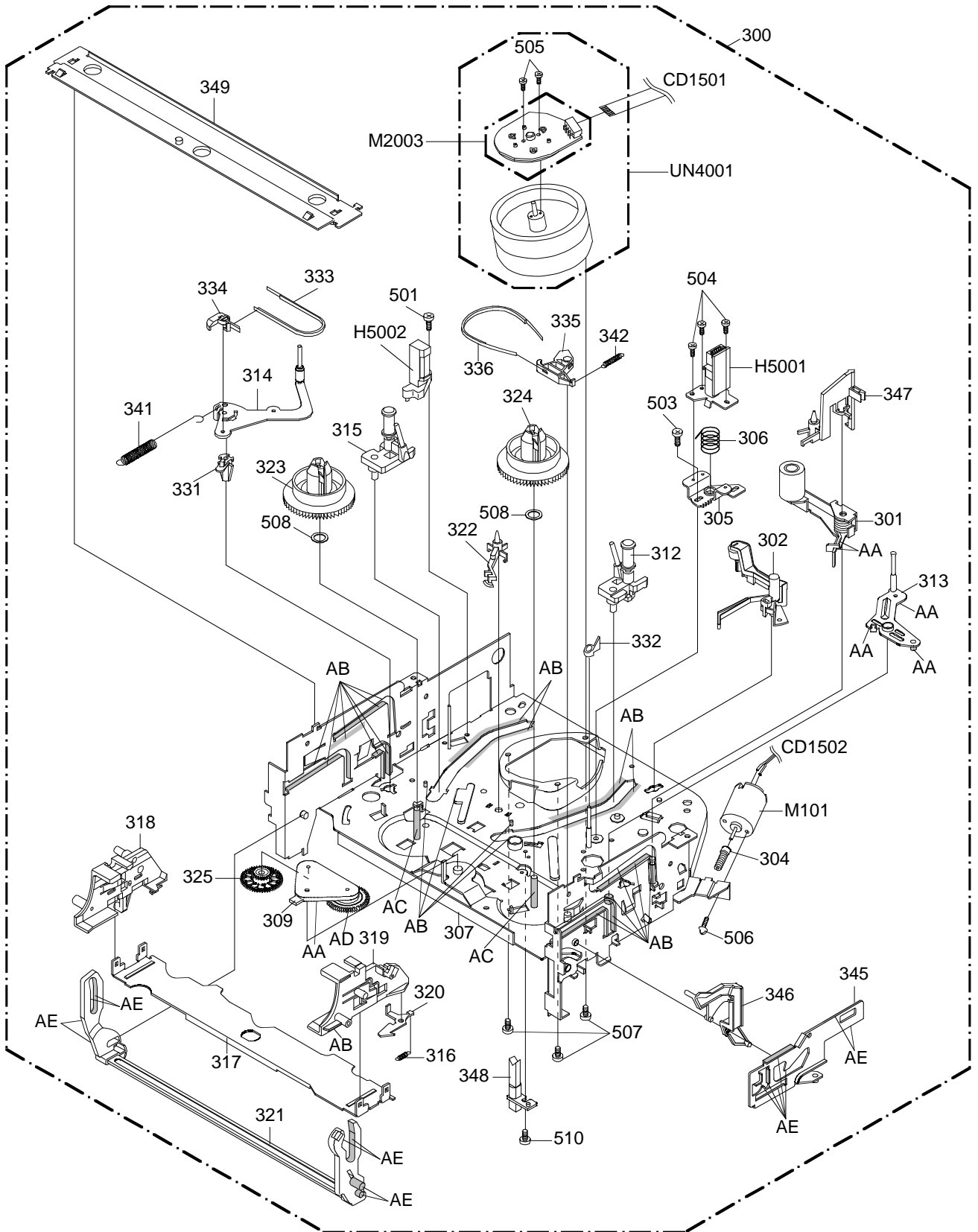

CLASS	PART NO.	PART NAME	MARK
GREASE	Y315061000	G-555G	AA
	Y315071000	MG-33	AB
	Y31D011000	FG-84M	AC
	Y315041000	FL-721	AD
	Y315141000	G-313Y	AE

NOTE: Applying positions AA, AB, AC, AD and AE for the grease are displayed for this section. Check if the correct grease is applied for each position.

CHASSIS EXPLODED VIEW (BOTTOM VIEW)

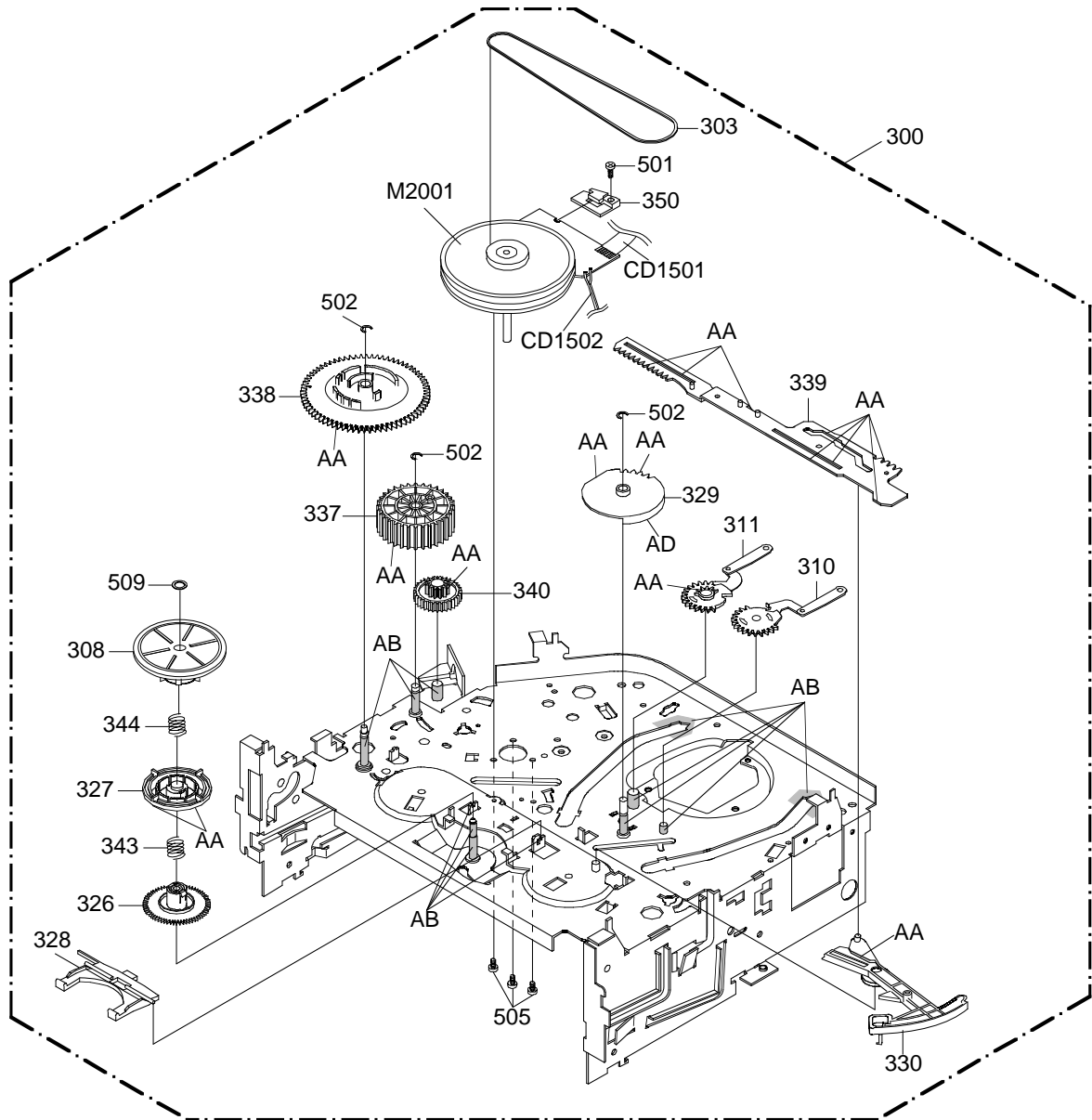

CLASS	PART NO.	PART NAME	MARK
GREASE	Y315061000	G-555G	AA
	Y315071000	MG-33	AB
	Y31D011000	FG-84M	AC
	Y315041000	FL-721	AD
	Y315141000	G-313Y	AE

NOTE: Applying positions AA, AB, AC, AD and AE for the grease are displayed for this section. Check if the correct grease is applied for each position.

DVD DECK EXPLODED VIEW

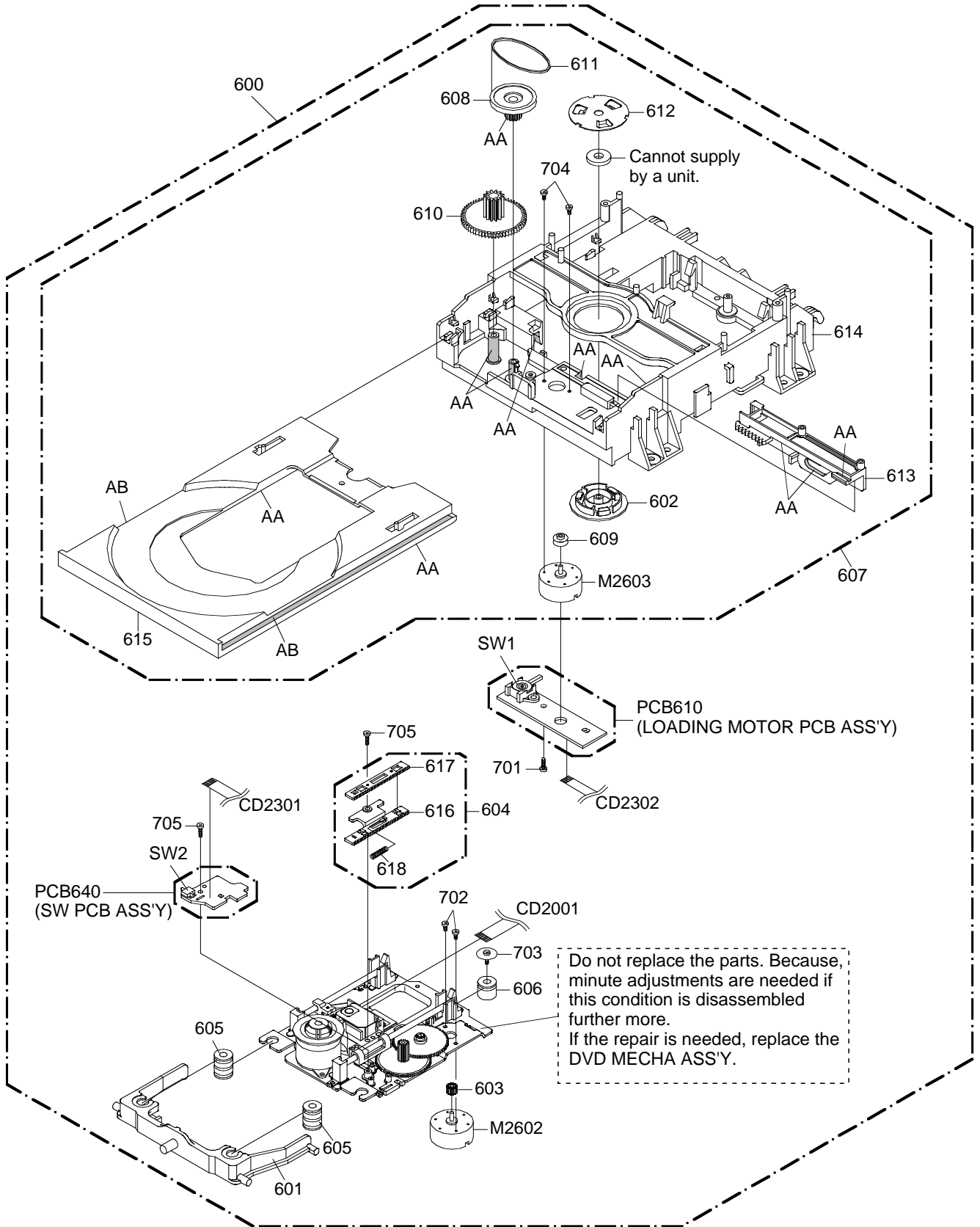

CLASS	PART NO.	PART NAME	MARK
GREASE	Y315061000	G-555G	AA
	Y315131000	SF-112	AB

NOTE: Applying positions AA and AB for the grease are displayed for this section.
Check if the correct grease is applied for each position.

MECHANICAL REPLACEMENT PARTS LIST

REF. NO.	PART NO.	DESCRIPTION		
101	7A701A193A	FRONT,CABI ASS'Y		
101A	701WPC786	CABINET,FRONT		
101B	712WPC058	FLAP,DVD		
101C	712WPC059	FLAP,VCR		
101D	713WPA0338	GLASS,LED1		
101E	713WPA0339	GLASS,LED2		
101F	713WPA0340	GLASS,LED3		
101G	713WPA0341	GLASS,LED-BUTTON		
101H	713WPA0342	GUIDE,REMOCON		
101I	738WPDA011	BUTTON,OPEN		
101J	738WPDA004	BUTTON,FRAME		
101K	738WPDA005	BUTTON,FRAME-CLASSIC		
101L	742WKA0001	SPRING,DVD-FLAP		
101M	743WKA0042	SPRING,FLAP		
101N	761WPA0335	HOOK,BOTTOM		
101O	761WPA0345	HOOK,TOP(L)		
101P	761WPA0346	HOOK,TOP(R)		
102	701WPA0686	HOLDER,DECK		
103	701WPA0751	HOLDER,DECK		
104	702WSA0212	CABINET, TOP		
105	761WPA0261	HOLDER,DVD BR		
106	85OP700038	HOLDER,END SENSOR		
107	702WSA0217	PLATE,BOTTOM		
108	722616A007	SHEET,RATING		
109	761WPA0321	HOLDER,DVD BL		
110	753WUA0065	SPRING,EARTH		
111	7260000341	SHEET,CAUTION		
	726000A073	SHEET,CAUTION		
112	761WPA0262	HOLDER,DECK TOP		
113	752WSA0290	SHIELD,COMPO		
114	702WPBA180	CABINET,BOTTOM		
115	725000A081	SHEET,BACK CL		
116	761WSAA025	ANGLE,FRONT		
117	702WPBA179	CABINET, TOP		
118	8965TS1010	CUSHION		
119	7A704A001A	LEG,CLASSIC (L)ASS'Y		
		65TS10-10(10x20x25)		
120	7A704A002A	LEG,CLASSIC (R)ASS'Y		
121	704WPA0033	LEG,BACK(L)		
122	704WPA0034	LEG,BACK(R)		
123	761WPA0332	HOLDER,BOTTOM		
201	8109130B9U	SCREW,TAP TITE(B)R	PAN	3x29
202	810923070U	SCREW,TAP TITE(B)R	BIND	3x7
203	8109I30A0U	SCREW,TAP TITE(B)	WH7	3x10
204	810923080U	SCREW,TAP TITE(B)	BIND	3x8
205	8109K3060U	SCREW,TAP TITE(B)	BIND(3D)	3x6
206	810713040U	SCREW,TAP TITE(S)	PAN	3x4
207	8110E2680U	SCREW,TAP TITE(P)	WH10	M2.6x8
208	810F13080U	SEMS(F)		3x8
209	810722660U	SCREW,TAP TITE(S)	BIND	2.6x6
210	811022680U	SCREW,TAP TITE(P)	BIND	2.6x8
211	8154D3033U	SCREW,TAP TITE(B)	WH8	3x33R
212	8110630A0U	SCREW,TAP TITE(P)	BRAZIER	3x10
---	J2D81221A	INSTRUCTION BOOK		
---	792WHA0561	PACKAGE, TOP		
---	792WHA0562	PACKAGE, BOTTOM		
---	793WCDC379	GIFT, BOX		
---	A2D812T975	INSTRUCTION BOOK KIT		
---	J3P90130A	DISNEY LEAFLET		
---	J3P90202B	WARRANTY SHEET(E/F)		
---	JB5U0300	POLYBAG, INSTRUCTION		

or

CHASSIS REPLACEMENT PARTS LIST

REF. NO.	PART NO.	DESCRIPTION	REF. NO.	PART NO.	DESCRIPTION
300	A2D801T420K	DECK ASSY A2D801T420K	501	8107226804	SCREW,TAP TITE(S) BIND 2.6x8
301	85OA400240	PINCH ROLLER BLOCK (VA)	502	83ETW30000	E-RING 3
302	85OA500026	AHC ASS'Y	503	8107226404	SCREW,TAP TITE(S) BIND 2.6x4
303	85OP200290	BELT,CAPSTAN (S)	504	8102120604	SCREW,PAN M2x6
304	85OP600581	WORM	505	8109126604	SCREW,TAP TITE(B) PAN 2.6x6
305	85OP500083	BASE,AC HEAD	506	810A130404	SCREW/WASHER(A) M3x4
306	85OP800324	SPRING,AC HEAD	507	810A126504	SCREW/WASHER(A) M2.6x5
307	85OA000516	MAIN CHASSIS ASS'Y	508	82Q264713N	POLYSLIDER WASHER 2.6x4.7xT0.13
308	85OA200089	CLUTCH ASS'Y	509	82P184505N	POLYSLIDER WASHER(CUT) 1.8x4.5xT0.5
309	85OA200090	ARM IDLER ASS'Y	510	8107226604	SCREW,TAP TITE(S) BIND 2.6x6
310	85OA300065	LOADING ARM S UNIT	CD1501	122H071704	CORD JUMPER 2H071704
311	85OA300066	LOADING ARM T UNIT	CD1502	122Y021902	CORD JUMPER 2Y021902
312	85OA400223	INCLINED BASE T UINIT 3S	H5001	1523Q91004	HEAD,AUDIO CONTROL VTR-1X2RPE22-772
313	85OA400232	P5 ARM ASS'Y 2	H5002	1543Q02014	HEAD (FULL ERASE) VTR-1X2ERS11-154
314	85OA400235	TENSION ARM ASS'Y 2	△ M101	1596S98001	MOTOR (LOADING) MDB2B66
315	85OA400231	INCLINED BASE S UNIT	△ M2001	1510S98042	CAPSTAN DD UNIT F2QVB73
316	85OP800367	SPRING LOCKER	M2003	1589S11020	MICRO MOTOR I2OAL34
317	85OP900736	CASS,HOLDER	△ UN4001	A5L1046500	CYLINDER UNIT ASS'Y A5L1046500
318	85OP900748	CASS,SIDE L			
319	85OP900749	CASS,SIDE R			
320	85OP900739	LOCKER,R			
321	85OA900228	LINK UNIT			
322	85OP000496	POST,CASS GUIDE			
323	85OP200316	REEL,S (S)			
324	85OP200317	REEL,T (S)			
325	85OP200308	GEAR,IDLER			
326	85OP200311	GEAR,CLUTCH			
327	85OP200312	GEAR,COUPLING			
328	85OP200313	LEVER,CLUTCH			
329	85OP300194	GEAR,MAIN LOADING			
330	85OP400490	LEVER,TENSION			
331	85OP400492	HOLDER,TENSION			
332	85OP400520	CAP.P4			
333	85OP400542	BAND,TENSION			
334	85OP400533	CONNECT,TENSION			
335	85OP600573	ARM,BRAKE T			
336	85OP600584	BAND,BRAKE T			
337	85OP600577	CAM,PINCH ROLLER			
338	85OP600578	CAM,MAIN			
339	85OP600579	ROD,MAIN			
340	85OP600582	GEAR,JOINT			
341	85OP800322	SPRING,TENSION			
342	85OP800360	SPRING,BRAKE T			
343	85OP800355	SPRING,COUPLING			
344	85OP800356	SPRING,RING			
345	85OP900743	LEVER,LINK			
346	85OP900744	LEVER,FLAP			
347	85OP900745	CASS,OPENER			
348	85OP700035	REFLECTOR,LED			
349	85OP900746	BRACKET,TOP 3V			
350	85OP400549	HOLDER,CAPSTAN			

DVD DECK REPLACEMENT PARTS LIST

REF. NO.	PART NO.	DESCRIPTION	
△ 600	A2D812T650	DVD MECHA ASS'Y	A2D812T650
601	92P100109A	HOLDER, TRAVERSE	
602	92P100094A	CLAMPER	
603	92P100088A	GEAR, MOTOR	
604	92AAA0014A	FEED RACK ASS'Y	
605	92P200013A	INSULATOR(F)	
606	92P200014A	INSULATOR(R)	
607	92SBB0019A	LOADER SUB ASS'Y	
608	92P100095A	GEAR, PULLEY	
609	92P100097A	PULLEY, MOTOR	
610	92P100096A	GEAR, MAIN	
611	92P200012A	BELT, LOADING	
612	92P000014A	PLATE, CLAMPER	
613	92P100093A	RACK, LOADING	
614	92P100091A	FRAME, MAIN	
615	92P100092A	TRAY	
616	92P100110A	RACK, FEED 1	
617	92P100090A	RACK, FEED 2	
618	92P300020A	SPRING, RACK FEED	
701	813381750U	SCREW, T-TITE(B) CAMERA PAN	M1.7x5.0 P3
702	814011723U	SCREW, PAN	M1.7x2.3 P3
703	816112080U	SEMS. TAP TITE(P) PAN	W10 2x8
704	814011730U	SCREW, PAN	M1.7x3 P3
705	811022080U	SCREW, TAP TITE(P) BIND	2x8
CD2001	122H001901	CORD JUMPER	2H001901
CD2301	122H062102	CORD JUMPER	2H062102
CD2302	122H052601	CORD JUMPER	2H052601
△ M2602	1515S98002	FEED MOTOR	BCZ3B03
△ M2603	1596S18002	LOADING MOTOR	BCZ3B52
PCB610	A5M4016610	PCB ASS'Y	DED003A
PCB640	A2E220T640	PCB ASS'Y	DED012A
SW1	0515S32002	SWITCH	SSS-13-2
SW2	0500101037	PUSH SWITCH	ESE22MH24

ELECTRICAL REPLACEMENT PARTS LIST

REF. NO.	PART NO.	DESCRIPTION	REF. NO.	PART NO.	DESCRIPTION
RESISTORS			ICS		
△ R501	R0G3K2335K	RC 3.3M OHM 1/2W	IC4002	I5HJ002AF0	IC S-24CS02AFJ-TB-G or
△ R502	R3X181010J	R,METAL OXIDE 1 OHM 1W		I5HJ002BF0	IC S-24C02BFJ-TB
△ R504	R002T2561J	RC 560 OHM 1/2W	IC4003	I0BF97KWM0	IC SI-3007KWM-TL
△ R512	R3X181683J	R,METAL OXIDE 68K OHM 1W	IC4005	IF3J00HGT7	IC HY57V641620HGT-7 or
△ R516	R63581R22J	R,FUSE 0.22 OHM 1W		IFLJ0632H7	IC K4S641632H-UC75
△ R517	R002T2102J	RC 1K OHM 1/2W	IC4007	ICMJ0800A8	IC SST39VF800A-70-4C-EK-D
CAPACITORS			IC8001	I0QJ045800	IC NJM4580M(TE1)
△ C501	E02LF2222M	CE 2200 UF 16V	IC8005	I0UF015010	IC MM1501XNRE
△ C502	P2122B224M	CMP 0.22 UF 275V ECQUL	IC8102	I17F017530	IC PCM1753DBQR
△ C505	E02LU2101M	CE 100 UF 16V	TRANSISTORS		
△ C511	E62QFC470M	CE 47 UF 200V	Q101	TCAA3875SY	TRANSISTOR SILICON KTC3875S_Y_RTK
△ C513	C03L0R7H2K	CC 220 PF 2KV R	Q102	TCAA3875SY	TRANSISTOR SILICON KTC3875S_Y_RTK
△ C514	E02LU2101M	CE 100 UF 16V	Q103	TPYJC05001	COMPOUND TRANSISTOR DTA124EKAT146
△ C515	C0J0B0514K	CC 0.01 UF 500V B	Q104	TCAT032034	TRANSISTOR, SILICON KTC3203_Y-AT
△ C516	CC3LE0MH3M	CC 0.0022UF 250V	Q105	TAATA12660	TRANSISTOR, SILICON KTA1266-AT(Y,GR)
△ C518	E61FF0222D	CE 2200 UF 6.3V	Q107	TAAA1504SY	TRANSISTOR SILICON KTA1504S_Y_RTK
△ C519	E02LF1222M	CE 2200 UF 10V	Q109	TCAA3875SY	TRANSISTOR SILICON KTC3875S_Y_RTK
△ C521	E02LU2101M	CE 100 UF 16V	Q301	TCAA3875SY	TRANSISTOR SILICON KTC3875S_Y_RTK
△ C522	E02LU5220M	CE 22 UF 50V	△ Q501	T25F035630	FET 2SK3563(ORION_Q)
△ C525	C0PLRR7U2K	CC 680 PF 2KV R	△ Q502	TCAT032034	TRANSISTOR, SILICON KTC3203_Y-AT
△ C526	CC3LE0MH3M	CC 0.0022UF 250V	△ Q503	TCAT03209Y	TRANSISTOR SILICON KTC3209_Y-AT
△ C540	E62QFC470M	CE 47 UF 200V	△ Q504	TAAT012714	TRANSISTOR, SILICON KTA1271_Y-AT
DIODES			△ Q505	TD3T012070	TRANSISTOR, SILICON 2SD1207(S,T)-AE
D501	D1VT001330	DIODE, SILICON 1SS133T-77	Q506	TNAAC05002	COMPOUND TRANSISTOR KRC103SRTK
△ D502	D2WXN40050	DIODE SILICON 1N4005-EIC	△ Q507	TCAT032034	TRANSISTOR, SILICON KTC3203_Y-AT
△ D503	D2WXN40050	DIODE SILICON 1N4005-EIC	Q509	TNYJC05001	COMPOUND TRANSISTOR DTC124EKAT146
D504	D1VT001330	DIODE, SILICON 1SS133T-77	△ Q510	TD3T012070	TRANSISTOR, SILICON 2SD1207(S,T)-AE
△ D505	D2WXN40050	DIODE SILICON 1N4005-EIC	Q513	T8YJ2412K0	TRANSISTOR SILICON 2SC2412KT146 R, S
△ D506	D2WXN40050	DIODE SILICON 1N4005-EIC	Q514	T8YJ2412K0	TRANSISTOR SILICON 2SC2412KT146 R, S
△ D507	D23TGP15J0	DIODE SILICON RGP15J-G23	Q666	TPYJC05001	COMPOUND TRANSISTOR DTA124EKAT146
D508	D1VT001330	DIODE, SILICON 1SS133T-77	Q668	TNYJC05001	COMPOUND TRANSISTOR DTC124EKAT146
D509	D2WXGP10J0	DIODE RECTIFIER RGP10J-EIC	Q2601	T67J1036K0	TRANSISTOR SILICON 2SA1036KT146
△ D510	D97U02201B	DIODE ZENER MTZJ22B T-77	Q2602	T67J048TL0	TRANSISTOR SILICON 2SA2048TL
△ D511	D2LKB340L0	DIODE SCHOTTKY SB340L-6737	Q2603	T27T030180	FET 2SK3018
D512	D1VT001330	DIODE, SILICON 1SS133T-77	Q2604	T27T030180	FET 2SK3018
△ D513	D2WXN40050	DIODE SILICON 1N4005-EIC	Q2605	T27T030180	FET 2SK3018
D514	D97U01201B	DIODE, ZENER MTZJ12B T-77	Q2606	TNYJC05001	COMPOUND TRANSISTOR DTC124EKAT146
△ D515	D28T21DQN4	DIODE SCHOTTKY 21DQ04N-TA2B1	Q2607	TAAA1504SY	TRANSISTOR SILICON KTA1504S_Y_RTK
D516	D97U05R11B	DIODE, ZENER MTZJ5.1B T-77	Q2608	TCAA3875SY	TRANSISTOR SILICON KTC3875S_Y_RTK
D518	D1VT001330	DIODE, SILICON 1SS133T-77	Q3002	0002700690	PHOTO COUPLER RPI-303
D519	D97U06R81B	DIODE, ZENER MTZJ6.8B T-77	Q3003	TPYJC05001	COMPOUND TRANSISTOR DTA124EKAT146
D520	D2WXN40050	DIODE SILICON 1N4005-EIC	Q3004	0002700680	PHOTO COUPLER RPI-352C40N
△ D522	D28TEL56N6	DIODE RECTIFIER 10EL56N-TA1B2	Q3005	0002700680	PHOTO COUPLER RPI-352C40N
△ D523	D97U03301B	DIODE, ZENER MTZJ33B T-77	Q3006	0000M00390	PHOTO TRANSISTOR ST-304L
D524	D1VT001330	DIODE, SILICON 1SS133T-77	Q3007	TNYJC05001	COMPOUND TRANSISTOR DTC124EKAT146
D526	D97U03R31B	DIODE, ZENER MTZJ3.3B T-77	Q3008	0000M00390	PHOTO TRANSISTOR ST-304L
D527	D2WXN40050	DIODE SILICON 1N4005-EIC	Q8001	TCAA3875SY	TRANSISTOR SILICON KTC3875S_Y_RTK
D528	D1VT001330	DIODE, SILICON 1SS133T-77	Q8002	TNYJD05001	COMPOUND TRANSISTOR DTC144EKAT146
D680	0021E2Q140	LED LTL-1CHEE-002A	Q8003	TNYJC05001	COMPOUND TRANSISTOR DTC124EKAT146
D681	0021E2Q140	LED LTL-1CHEE-002A	Q8004	TAATA12660	TRANSISTOR, SILICON KTA1266-AT(Y,GR)
D682	0021E2Q140	LED LTL-1CHEE-002A	Q8005	TCAA3875SY	TRANSISTOR SILICON KTC3875S_Y_RTK
D683	0021E2Q140	LED LTL-1CHEE-002A	Q8006	TCAA3875SY	TRANSISTOR SILICON KTC3875S_Y_RTK
D684	0021E2Q140	LED LTL-1CHEE-002A	Q8007	TPYJC05001	COMPOUND TRANSISTOR DTA124EKAT146
D685	0021E5Q210	LED LTL-1CHGE-002A	Q8008	TCAA3875SY	TRANSISTOR SILICON KTC3875S_Y_RTK
D2601	DDARDS1200	DIODE SILICON KDS120RTE	Q8009	TCAA3875SY	TRANSISTOR SILICON KTC3875S_Y_RTK
D2602	DE5RB2R21X	DIODE ZENER 02DZ2.2-X(TH3ORION	Q8010	TPYJA05001	COMPOUND TRANSISTOR DTA143EKAT146
D3001	0010E00330	INFRARED LED LTE-3271T-012A-O	Q8011	TNYJC05001	COMPOUND TRANSISTOR DTC124EKAT146
D3002	D1VT001330	DIODE, SILICON 1SS133T-77	Q8012	TCAA3875SY	TRANSISTOR SILICON KTC3875S_Y_RTK
D3007	D1VT001330	DIODE, SILICON 1SS133T-77	COILS & TRANSFORMER		
D3009	D1VT001330	DIODE, SILICON 1SS133T-77	L101	031626010R	COIL, BIAS OSC 1626010
D8004	D1VT001330	DIODE, SILICON 1SS133T-77	L102	02167F101J	COIL 100 UH
D8005	D1VT001330	DIODE, SILICON 1SS133T-77	L301	02167F220J	COIL 22 UH
D8006	D1VT001330	DIODE, SILICON 1SS133T-77	△ L501	029X000117	COIL, LINE FILTER SS11VL-05230
D8111	DDDRL41480	DIODE SILICON MCL4148	L505	02167F220J	COIL 22 UH
D8112	DDDRL41480	DIODE SILICON MCL4148	L506	021W7A220K	COIL 22 UH
ICS			L701	021LA6220J	COIL 22 UH
IC101	I03F3206M0	IC LA71206M-MPB	L702	021LA6220J	COIL 22 UH
△ IC501	I0CJ9AILP0	IC TL431AILP	L703	02167F220J	COIL 22 UH
△ IC502	I1KA98R09A	IC KIA78R09API	L704	02167F220J	COIL 22 UH
△ IC503	000220002W	PHOTO COUPLER PS2561AL1-1-V(W)	L705	02167F220J	COIL 22 UH
IC701	I03F670BM0	IC LA72670BM-L-MPB-E	L3002	021W7A220K	COIL 22 UH
IC2301	I03F065650	IC LA6565-TE-L-E	L3003	021LA6120J	COIL 12 UH
IC2601	ICQK067080	IC ZR36708TQC	L4001	02167F2R2J	COIL 2.2 UH
IC3001	I54F50147A	IC OEC0147A	L8001	021LA6R33M	COIL 0.33 UH
IC3003	I9UF032310	IC PST3231NR	L8002	021LA6R33M	COIL 0.33 UH
IC3099	A2D812T015	INIT DATA	L8102	02167F1R0K	COIL 1 UH
IC4001	ICQK06762V	IC ZR36762PQCG_V or	L8103	02167F1R0K	COIL 1 UH

ELECTRICAL REPLACEMENT PARTS LIST

REF. NO.	PART NO.	DESCRIPTION	REF. NO.	PART NO.	DESCRIPTION
COILS & TRANSFORMER			MISCELLANEOUS		
L8104	02167F1R0K	COIL 1 UH	NR4004	110P4101M4	R.NETWORK 4D03WJ0101T5E
L8105	02167F1R0K	COIL 1 UH	NR4005	110P4101M4	R.NETWORK 4D03WJ0101T5E
△ T501	0481291244	TRANSFORMER, SWITCHING 81291244	NR4006	110P4101M4	R.NETWORK 4D03WJ0101T5E
JACKS			NR4007	110P4101M4	R.NETWORK 4D03WJ0101T5E
J8001	060J411031	RCA JACK MSP-213V1-432_NI_LF	NR4008	110P4101M4	R.NETWORK 4D03WJ0101T5E
J8006	060J411033	RCA JACK MSP-213V1-732_NI_LF	OS680	077Q037002	REMOTE RECEIVER PIC-37143TH5
J8008	063D700008	JACK MDC-070V-B_LF	TM601	076R0JT010	TRANSMITTER R56-0538
SWITCHES			△ TU301	0162300042	RF UNIT 115-V-H035ARE
SW680	0504R01T38	SWITCH TACT EVQ11L05R	X101	100DT3R528	CRYSTAL HC-49/U
SW681	0504R01T38	SWITCH TACT EVQ11L05R	X3001	100GT01006	CRYSTAL B10000C001
SW682	0504R01T38	SWITCH TACT EVQ11L05R	X4001	100BT02701	CRYSTAL HC-49U/S
SW683	0504R01T38	SWITCH TACT EVQ11L05R			
SW684	0504R01T38	SWITCH TACT EVQ11L05R			
SW685	0504R01T38	SWITCH TACT EVQ11L05R			
SW686	0504R01T38	SWITCH TACT EVQ11L05R			
SW687	0504R01T38	SWITCH TACT EVQ11L05R			
SW688	0504R01T38	SWITCH TACT EVQ11L05R			
SW689	0504R01T38	SWITCH TACT EVQ11L05R			
SW690	0504R01T38	SWITCH TACT EVQ11L05R			
SW3001	0508S11001	SWITCH (LEAF) LSA-1144EAU			
P.C. BOARD ASSEMBLIES					
PCB010	A2D812T010	PCB ASS'Y VMD335A			
PCB130	A2D812T130	PCB ASS'Y VMD342A			
PCB270	A2D812T270	PCB ASS'Y VEDA51A			
PCB280	A2D812T280	PCB ASS'Y VEDA52A			
MISCELLANEOUS					
B501	024HT03563	CORE, BEADS W4BRH3.5X6X1.0X2			
B701	024HT03553	CORE, BEADS W5RH3.5X5X1.0			
B2601	024HC31022	CORE, BEADS FCM2012H-102T04			
B2602	024HC31022	CORE, BEADS FCM2012H-102T04			
B2603	024HC31022	CORE, BEADS FCM2012H-102T04			
B2604	024HC31022	CORE, BEADS FCM2012H-102T04			
B2605	024HC31022	CORE, BEADS FCM2012H-102T04			
B4001	024HC31022	CORE, BEADS FCM2012H-102T04			
B4002	024HC31022	CORE, BEADS FCM2012H-102T04			
B4003	024HC31022	CORE, BEADS FCM2012H-102T04			
B4004	024HC31022	CORE, BEADS FCM2012H-102T04			
B4005	024HC31022	CORE, BEADS FCM2012H-102T04			
B4006	024HC31022	CORE, BEADS FCM2012H-102T04			
B4007	024HC31022	CORE, BEADS FCM2012H-102T04			
B4008	024HC31022	CORE, BEADS FCM2012H-102T04			
B4010	024HC31022	CORE, BEADS FCM2012H-102T04			
B8002	024HC31022	CORE, BEADS FCM2012H-102T04			
B8003	024HC31022	CORE, BEADS FCM2012H-102T04			
B8103	024HC31022	CORE, BEADS FCM2012H-102T04			
CD102	122F041508	CORD JUMPER 2F041508			
△ CD501	1209414910	CORD AC BUSH 9414910			
CD680	122H050801	CORD JUMPER 2H050801			
CD682	122H011001	CORD JUMPER 2H011001			
CP101	0697290620	CONNECTOR PCB SIDE TOC-C09X-A1			
CP102	069J740599	CONNECTOR PCB SIDE IMSA-9604S-04C			
CP103	067U002019	WIRE HOLDER B2013H02-2P			
CP501	069S2B0629	CONNECTOR PCB SIDE A2001WV2-11P			
CP651	069J750589	CONNECTOR PCB SIDE IMSA-9604S-05F			
CP652	069EVI3010	CONNECTOR PCB SIDE 00_6232_018_006_800			
CP680	069J750589	CONNECTOR PCB SIDE IMSA-9604S-05F			
CP682	069EVI3020	CONNECTOR PCB SIDE 00_6232_018_102_8			
CD4002	06CU2B1101	CORD CONNECTOR CU2B1101 or			
	06C32B1103	CORD CONNECTOR C32B1103			
CD6002	06CPL02006	CABLE CPL02006			
CD6003	06CPBA2003	CORD, RCA PIN TD-020301-3			
CD8001	122F0E1001	CORD JUMPER 2F0E1001			
CP2601	069GYOT119	CONNECTOR PCB SIDE 09-5000-024-001-001			
CP2602	069EV53010	CONNECTOR PCB SIDE 00_6232_005_006_800			
CP2603	069EV63010	CONNECTOR PCB SIDE 00_6232_006_006_800			
CP3001	06972C0010	CONNECTOR PCB SIDE TMC-J12P-B2			
CP681A	067U003029	WIRE HOLDER B2013H02-3P			
CP681B	067U003029	WIRE HOLDER B2013H02-3P			
CP8001	069J7E0599	CONNECTOR PCB SIDE IMSA-9604S-14C			
CP8101	069J7E0589	CONNECTOR PCB SIDE IMSA-9604S-14F			
△ F501	081PC2R505	FUSE 51MS025L			
FH501	06710T0009	HOLDER, FUSE EYF-52BCY			
FH502	06710T0009	HOLDER, FUSE EYF-52BCY			
NR4001	110P4101M4	R, NETWORK 4D03WJ0101T5E			
NR4002	110P4101M4	R, NETWORK 4D03WJ0101T5E			
NR4003	110P4101M4	R, NETWORK 4D03WJ0101T5E			

SPEC.NO.	M2D8-12T
O/R NO.	K482001